

eCalendar

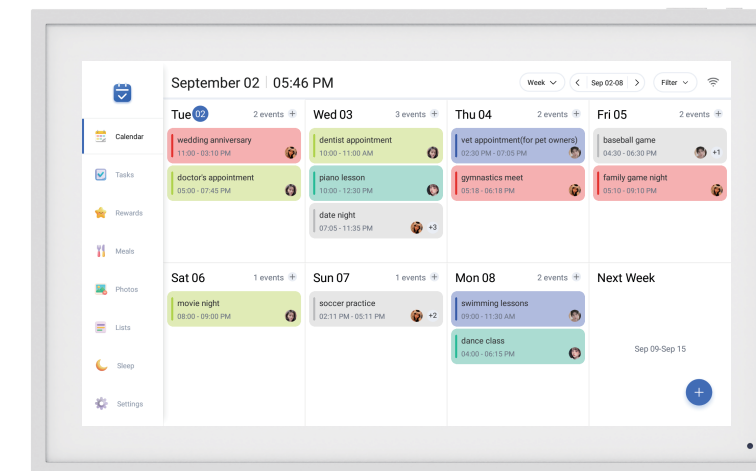

User Manual

Wifi Digital Calendar for Family Schedules

eCalendar

Download the eCalendar App



Cautions

Precautions and Maintenance

- For indoor use only.
- To avoid risk of fire or electric shock, do not expose the unit to moisture or condensation.
- To avoid overheating, do not block the ventilation holes on the back of the Digital Calendar.
- Keep the Digital Calendar out of direct sunlight.
- Do not dismantle the Digital Calendar. There is a risk of electric shock and there are no user-serviceable parts inside. Dismantling the Digital Calendar will void your warranty.

Cleaning the LCD Screen

- Treat the screen carefully. Because the screen of the Digital Calendar is made of glass and it would be broken or scratched easily.
 - If fingerprints or dust accumulate on the LCD screen, we recommend using a soft, non-abrasive cloth such as a camera lens cloth to clean the LCD screen.
- Moisten the cleaning cloth with the cleaning solution and apply the cloth to the screen.

Cautions

WARNING:

To reduce the risk of electric shock, do not expose the unit to rain or excessive moisture.

This device is intended for private use and not suitable for commercial use!

Introduction

Congratulations on your eCalendar purchase! We are excited to help you lighten the mental load of keeping track of everyone's busy schedules so you can get back to enjoying what matters most to your family. We are always looking to improving and evolve our product, new features will be downloaded automatically to your device or mobile app, and you'll be notified through emails , push notifications, and in-app messages.

Contents

1.10\15.6\21.5\24\27\32” Digital Calendar for Family Schedules Overview	05
2. Getting Started	17
2.1 Get the App and Create Account	17
2.2 Syncing a New Calendar	20
2.2.1 Syncing a Local Calendar on Your Phone	21
2.2.2 Deleting a Synced Calendar	22
2.2.3 Unbind activation code	22
2.2.4 Syncing Google Calendar/iCloud Calendar/Yahoo! / Cozi /Calendar UCRL / Subscribed Calendar	23
3.Operation Instruction	30
3.1 Events	30
3.1.1 Viewing Events-APP	30
3.1.2 Viewing Events-Device	31
3.1.3 Creating Events	33
3.1.4 Recurring Events	34
3.1.5 Edit Event	37
3.2.1 User management	38

Contents

3.2.2 Create Tasks	44
3.3 Rewards	51
3.4 Meals	58
3.5 Photo & Video	67
3.6 Lists	71
3.7 Profiles	76
3.8 Weather	84
4.Magic Import	85
5.Sleep Mode	85
6.Settings	87
7.Installation Instruction	89
8.Technical Specifications & Features	91
9.Warranty & Contact Us	92
10.Troubleshooting Guide	93
11.Firmware Upgrade Instructions	97

10.1" Digital Calendar For Family Schedules Overview

10.1" Digital Calendar For Family Schedules

- 1 Digital Calendar
- 2 Power On/Off Button
- 3 Volume up and down
- 4 Bracket
- 5 DC IN

10.1" Digital Calendar For Family Schedules Overview

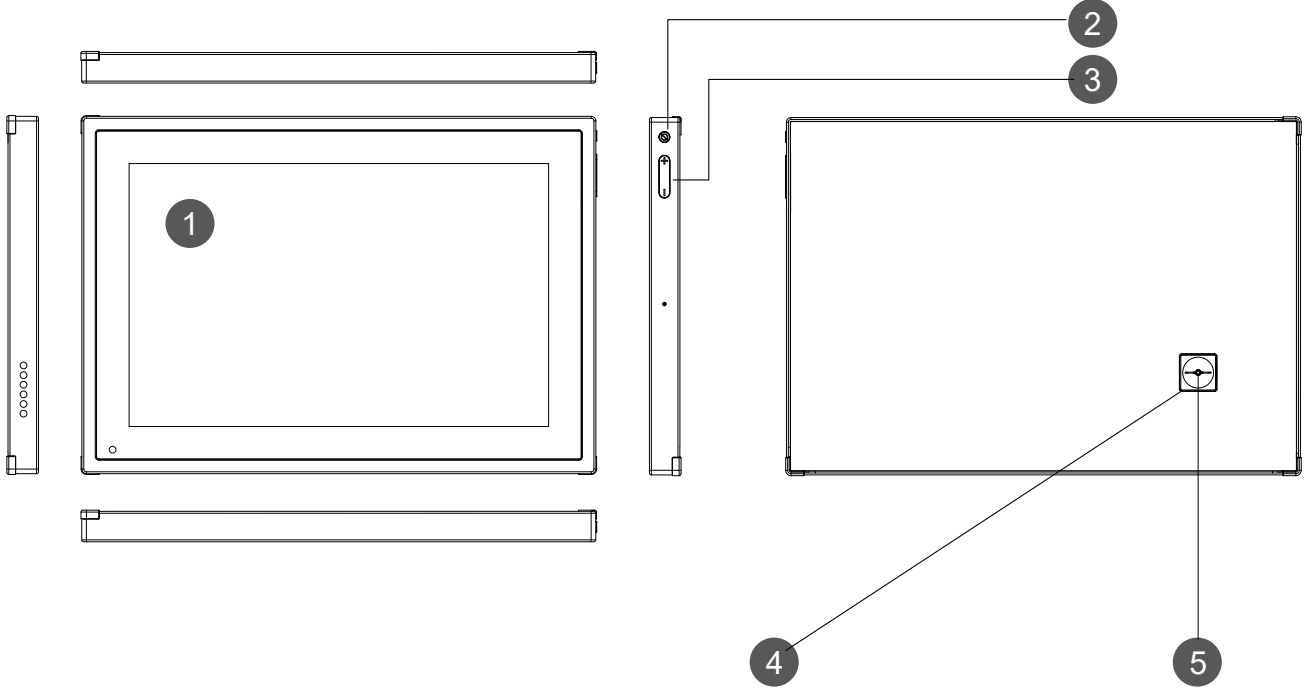

15.6" Digital Calendar For Family Schedules Overview

15.6" Digital Calendar For Family Schedules

- 1 Digital Calendar
- 2 Power On/Off Button
- 3 Volume up and down
- 4 Bracket
- 5 DC IN

15.6" Digital Calendar For Family Schedules Overview

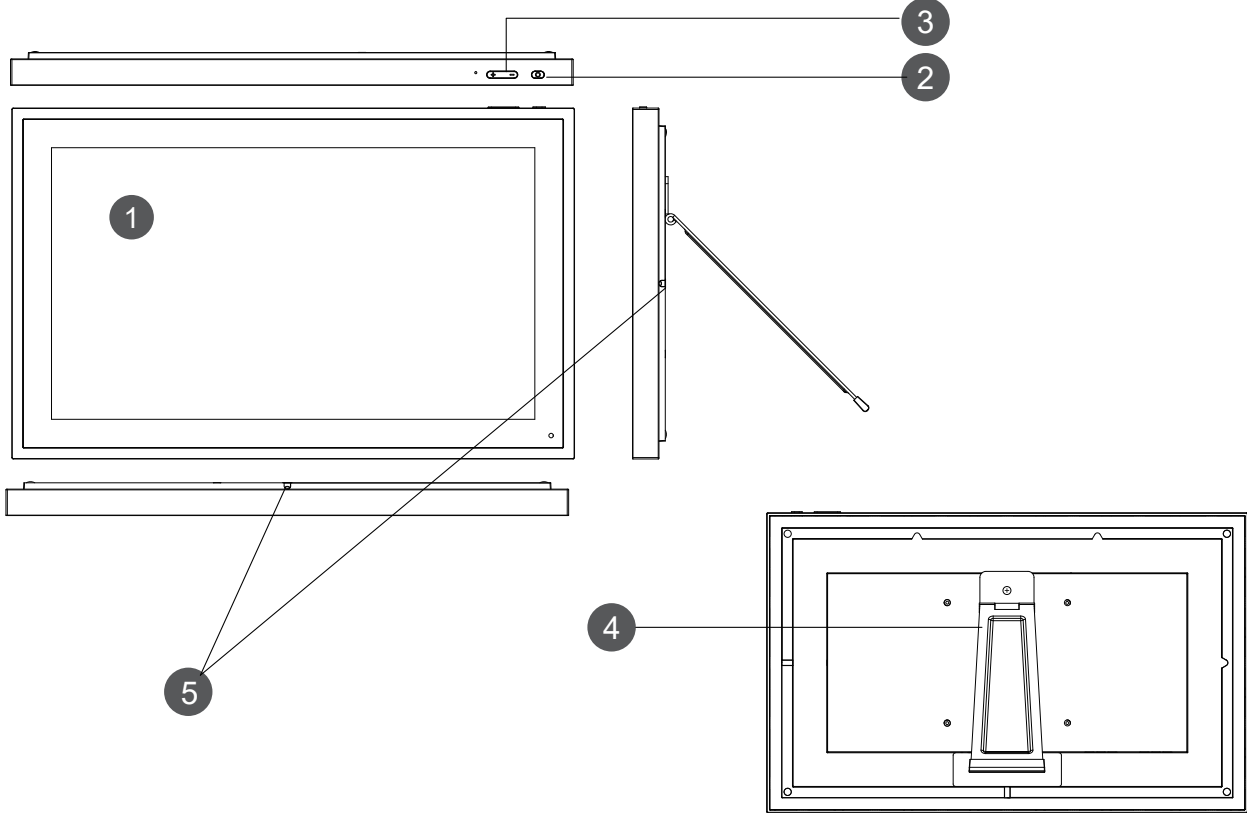

21.5" Digital Calendar For Family Schedules Overview

21.5" Digital Calendar For Family Schedules

- ① Digital Calendar
- ② Power On/Off Button
- ③ Volume up and down
- ④ Bracket
- ⑤ DC IN

21.5" Digital Calendar For Family Schedules Overview

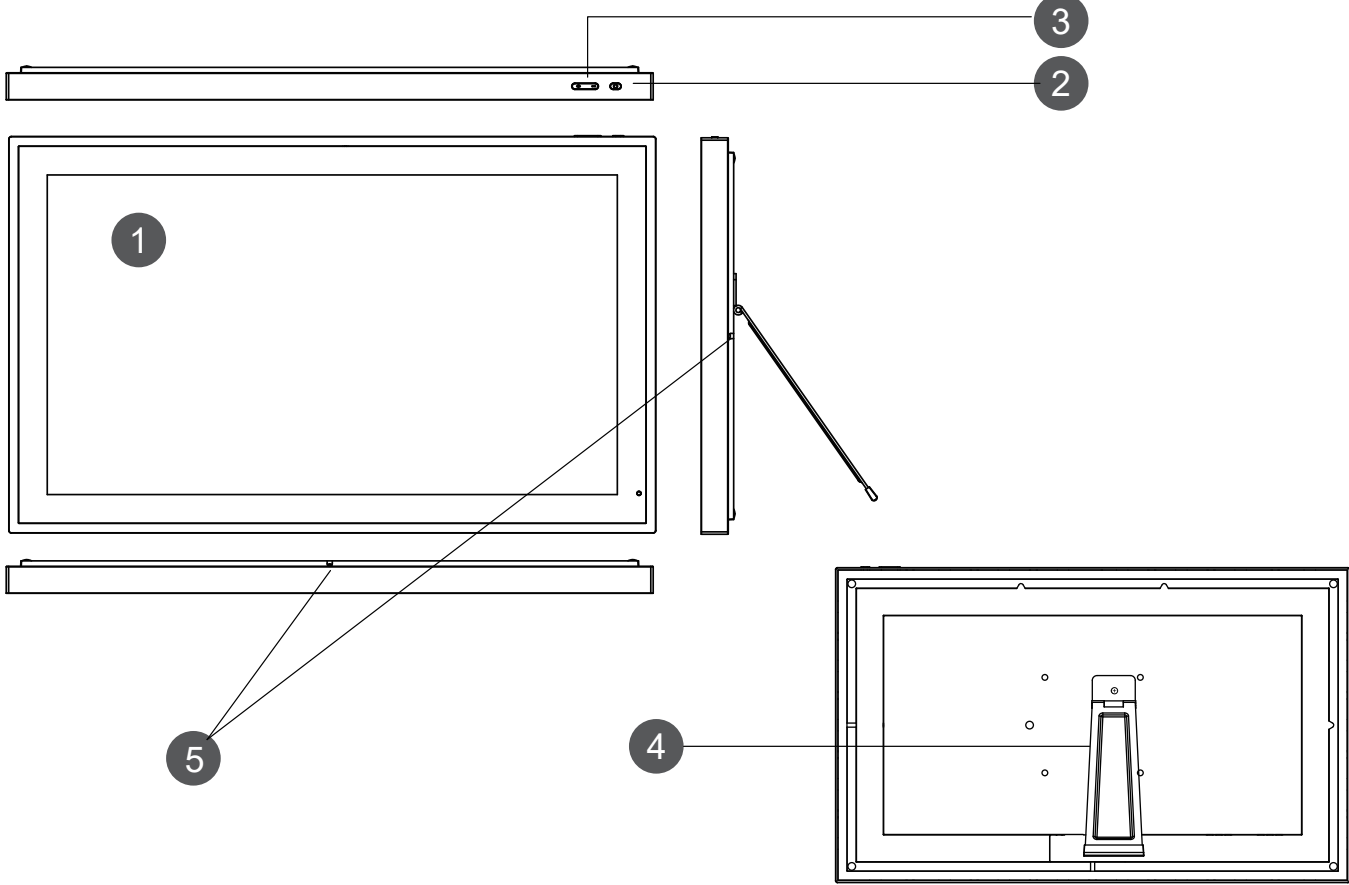

24" Digital Calendar For Family Schedules Overview

24" Digital Calendar For Family Schedules

- 1 Digital Calendar
- 2 Power On/Off Button
- 3 Volume up and down
- 4 Rotate Bracket
- 5 Speaker
- 6 TYPE-C
- 7 DC IN
- 8 Upgrade Hole
- 9 Vesa Hole

24" Digital Calendar For Family Schedules Overview

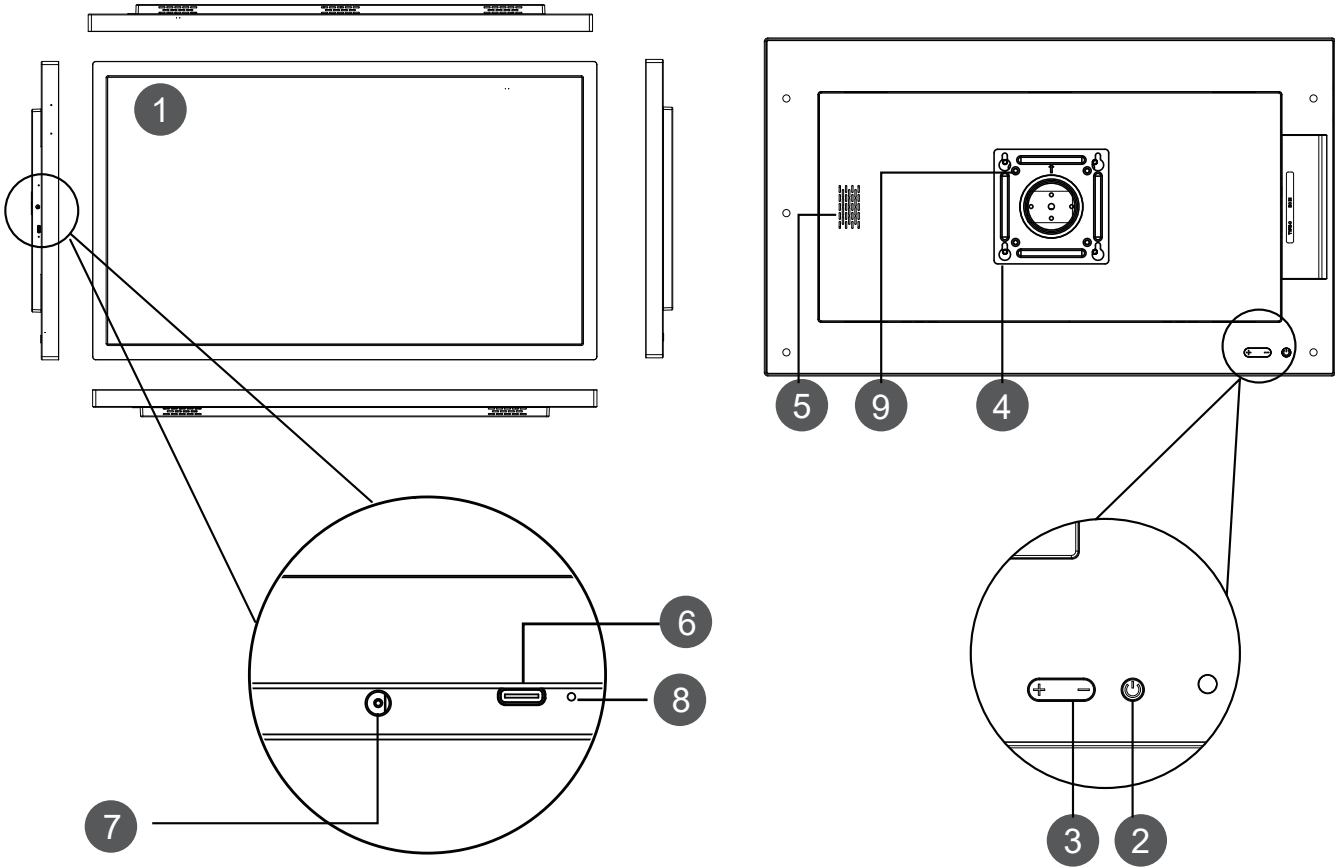

27" Digital Calendar For Family Schedules Overview

27" Digital Calendar For Family Schedules

- 1 Digital Calendar
- 2 Power On/Off Button
- 3 Volume up and down
- 4 Rotate Bracket
- 5 Speaker
- 6 TYPE-C
- 7 DC IN
- 8 Upgrade Hole
- 9 Vesa Hole

27" Digital Calendar For Family Schedules Overview

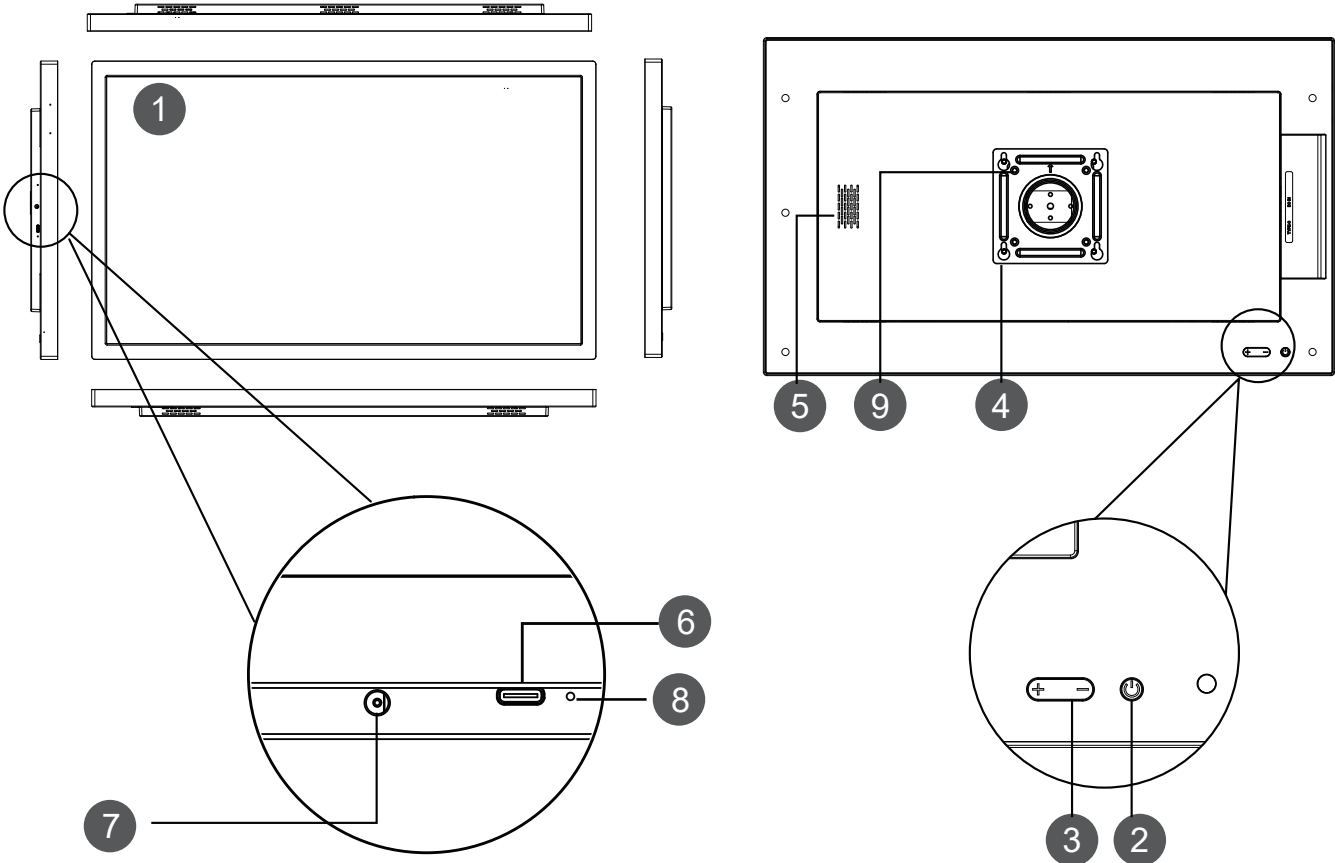

32" Digital Calendar For Family Schedules Overview

32" Digital Calendar For Family Schedules

- | | |
|-----------------------|----------------|
| 1 Digital Calendar | 6 TYPE-C |
| 2 Power On/Off Button | 7 DC IN |
| 3 Volume up and down | 8 Upgrade Hole |
| 4 Rotate Bracket | 9 Vesa Hole |
| 5 Speaker | |

32" Digital Calendar For Family Schedules Overview

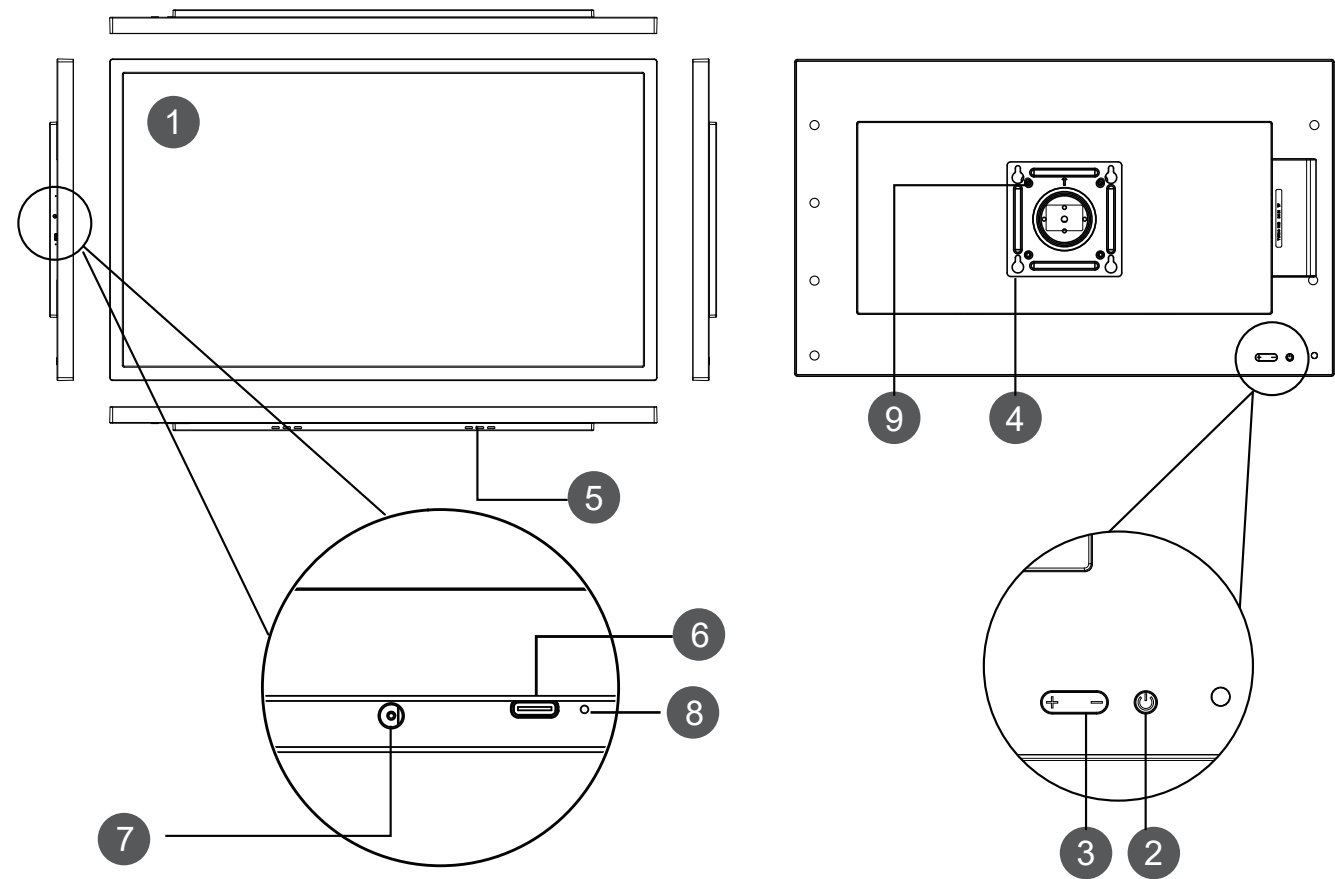

2. Getting Started

2.1.1 Get the App and Create Account

You'll need the free eCalendar app to use the features of your eCalendar to their full potential. Download the app on Google Play or APP Store and get started.

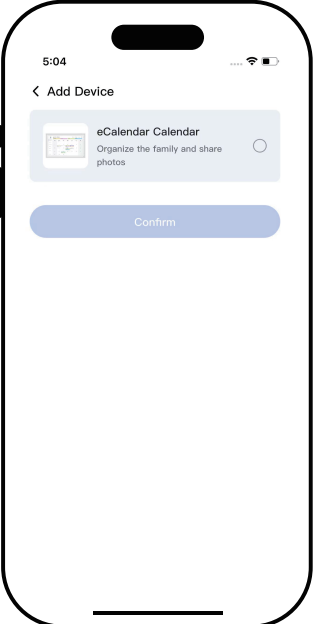
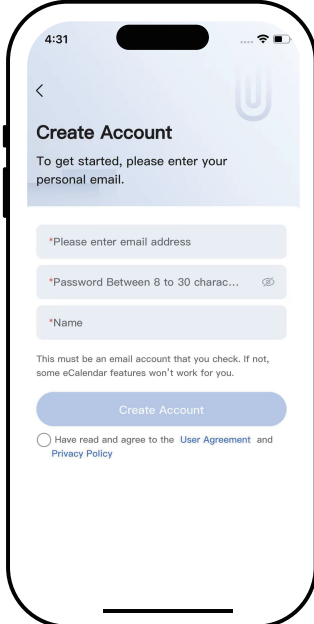
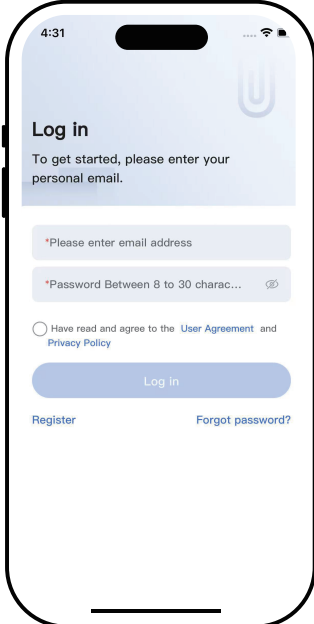

2. Getting Started

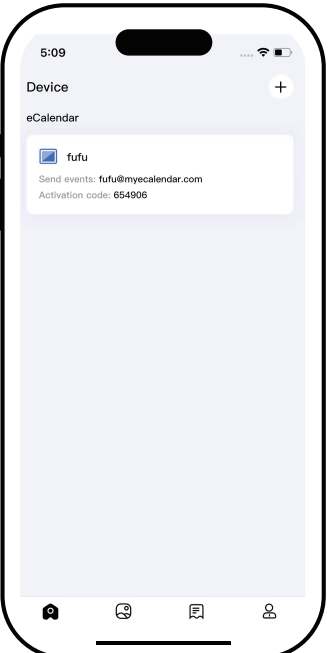
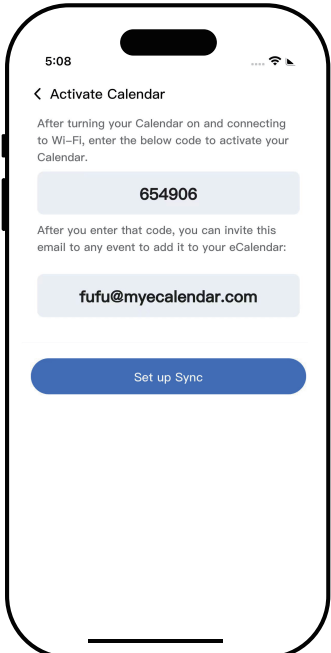
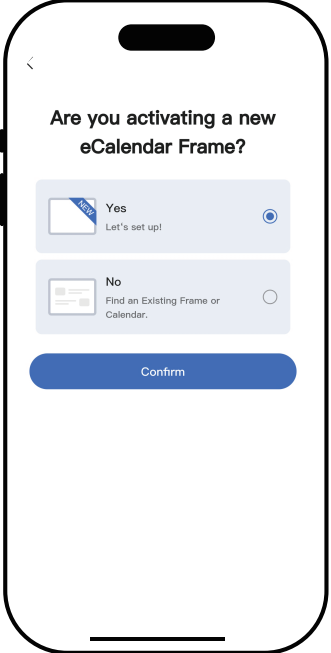

2. Getting Started

2.1.2 Initial Setup on Device

Turn on your eCalendar, select (your preferred) language, connect to wifi and choose the time zone and city, then enter your 6-digit activation code to get started. (PS:The weather function is activated only after you select the city.) Click “here”, you can view the version of the device without entering the activation code.

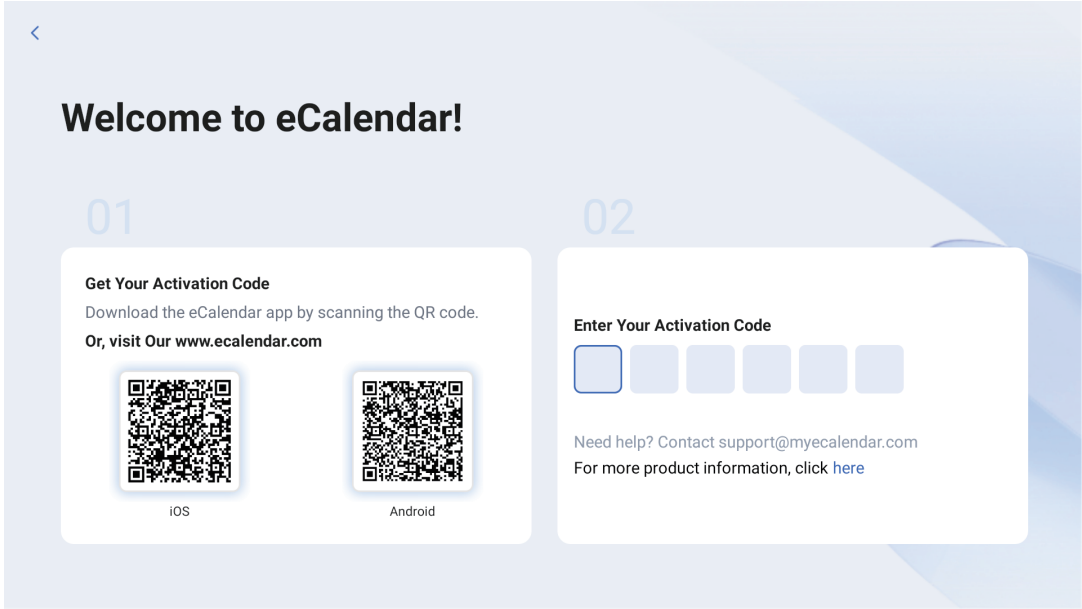

2. Getting Started

2.2 Syncing a New Calendar

Syncing can only be done through the app. When you sync a source calendar, (such as Google, iCloud, Outlook) with eCalendar any changes on your source calendar will automatically show up on the digital calendar.

1. Open Sync on the home screen.
2. Select "Sync a New Calendar".

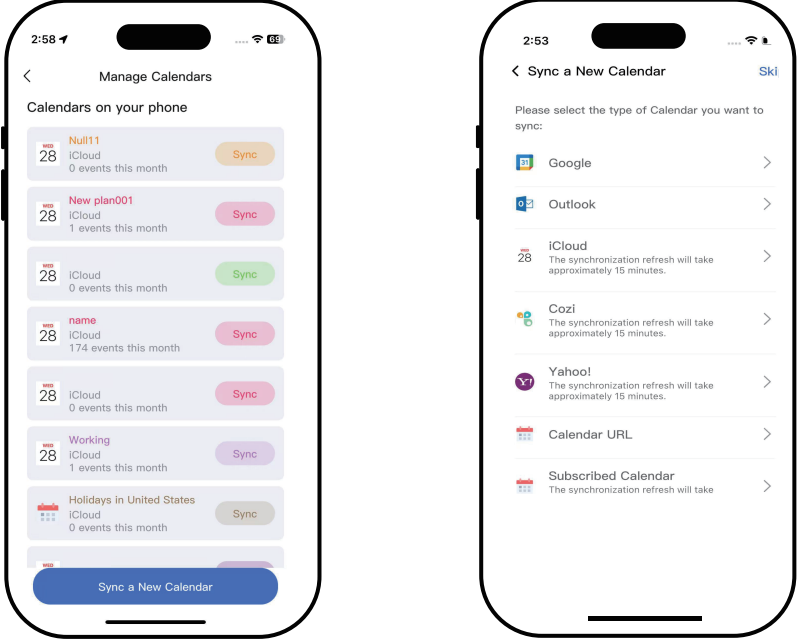

2. Getting Started

2.2.1 Syncing a Local Calendar on Your iPhone

1. Please first have access to a local calendar on your iPhone, not available on Android phones.
2. Choose a local calendar and press Sync to start the syncing process.

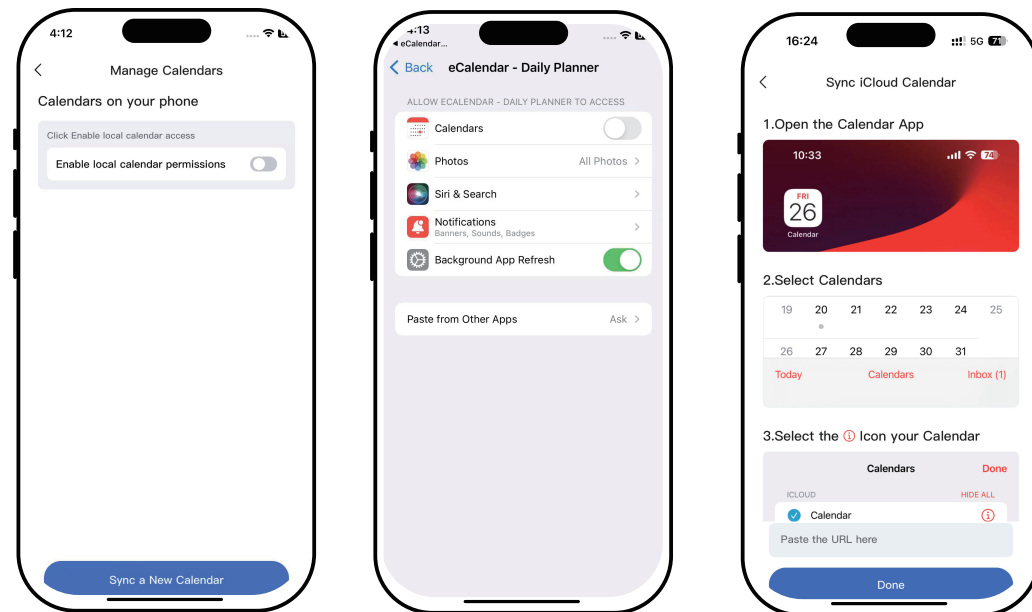

- 21 -

2. Getting Started

2.2.2 Deleting a Synced Calendar

1. Tap on the synced calendar
 2. Select "Unsync" to delete the synced calendar
- The Profiles associated with your synced calendar will still remain after you remove your synced calendar. You will need to delete the Profiles separately.

2.2.3 Unbind activation code

1. For the activation code that has logged into the device, swipe left and the Unbind button will appear.
2. Click "Confirm" to exit the login status in the device.

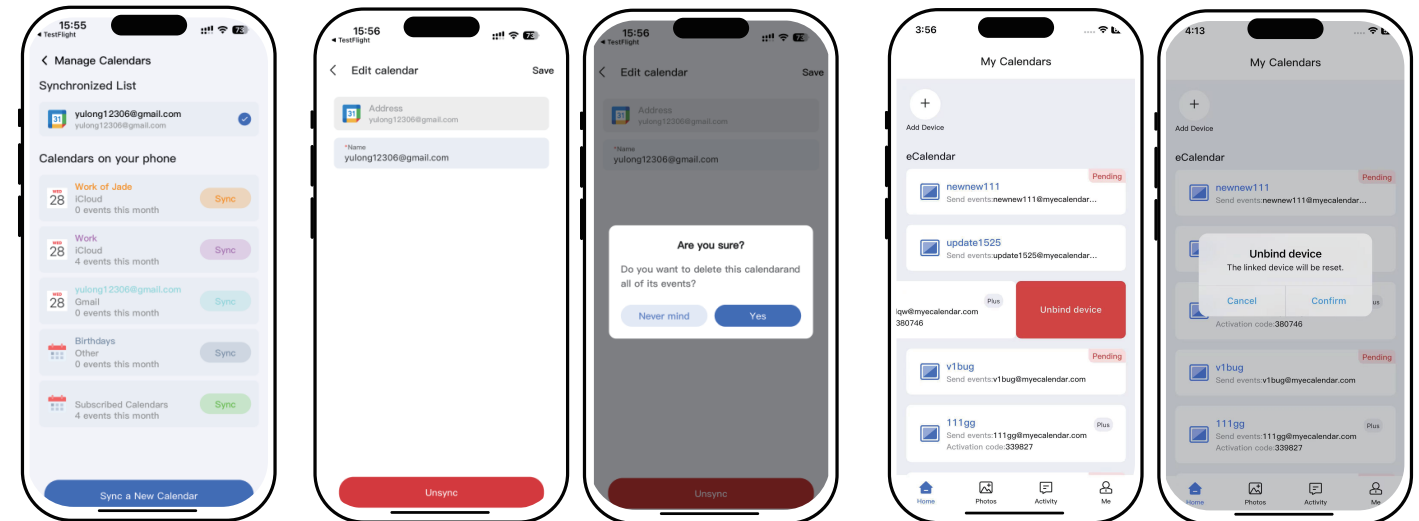

2.2.2 -1

2.2.2 -2

- 22 -

2.2.3 -1

2.2.3 -2

2. Getting Started

2.2.4 Syncing Google Calendar

If you're syncing a work calendar that uses Google Workspace, select Google.

1. Choose Two-ways sync or One-way sync as you need.
2. Choose the account you want to sync.
3. Wait for your calendars to download.
4. Wait for successful upload or back to home
5. Tap "See Events" to complete process.
6. It's done.

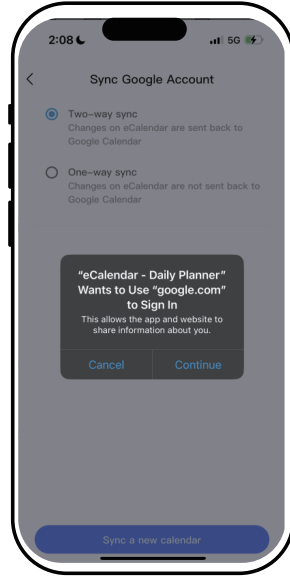

1

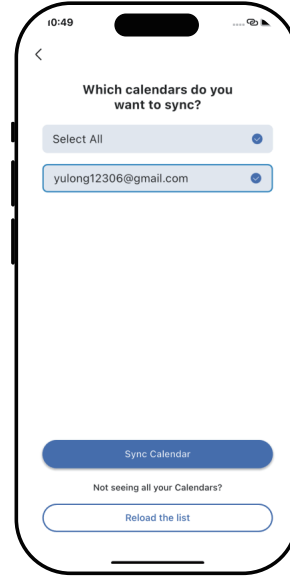

2

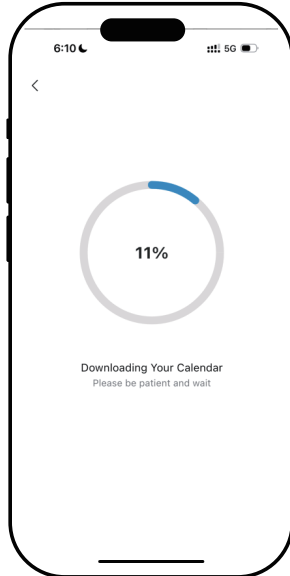

3

2. Getting Started

7. When the yellow exclamation mark appears in the synchronization section, it indicates that the previous synchronization calendar has expired.
8. There are three states for synchronizing calendars, namely, synchronizing, synchronized and expired.

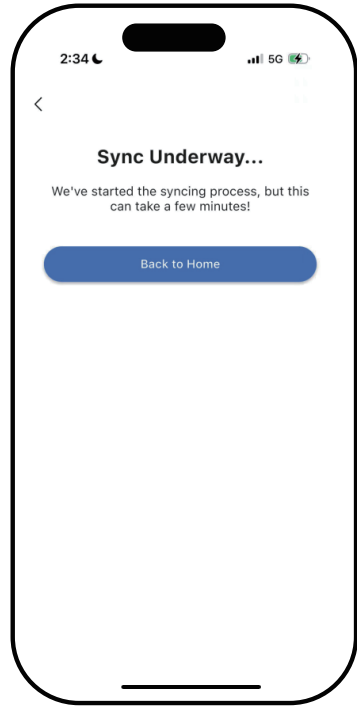

4

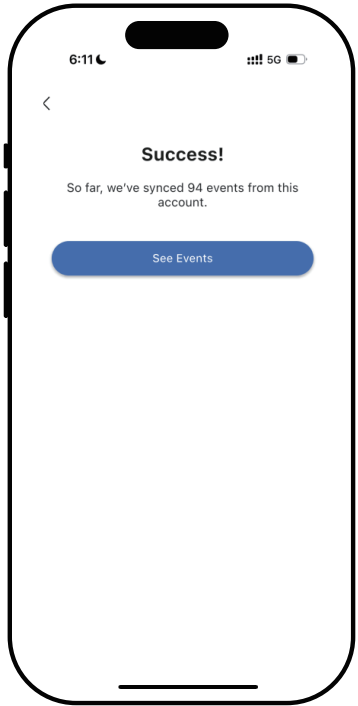

5

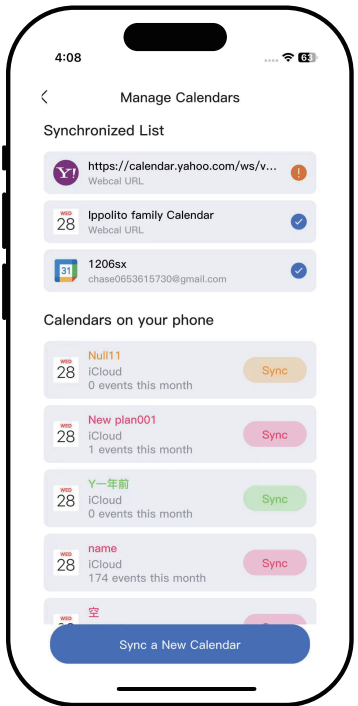

6

2. Getting Started

2.2.5 Syncing iCloud Calendar

1. Open the Calendar app.
2. Select Calendars at the bottom.
3. Select the  icon next to the calendar you want to sync.
4. Enable Public Calendar and select Share Link.
5. Email the Share Link to your calendar address (e.g., leann123@myeCalendar.com)



1

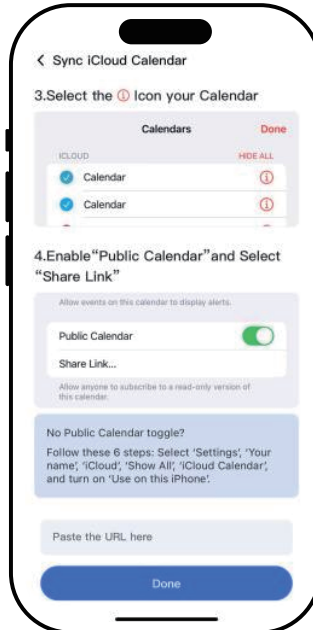

2

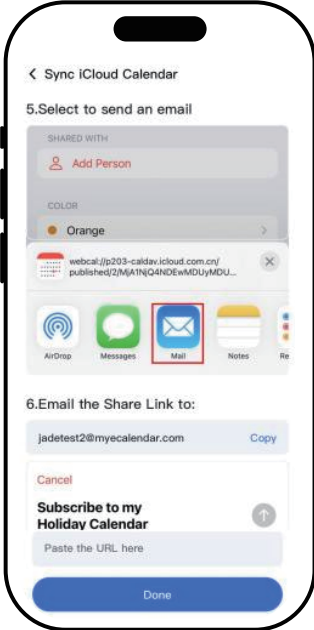

3

2. Getting Started

2.2.6 Syncing Yahoo/Cozi/Calendar URL/Subscribed Calendar

If Yahoo, Cozi, Calendar URL, and Subscribed calendar are to be synchronized, there will be appropriate operation steps when Subscribed Calendar is clicked to synchronize the new calendar (for details, see the corresponding detailed description in eCalendar).

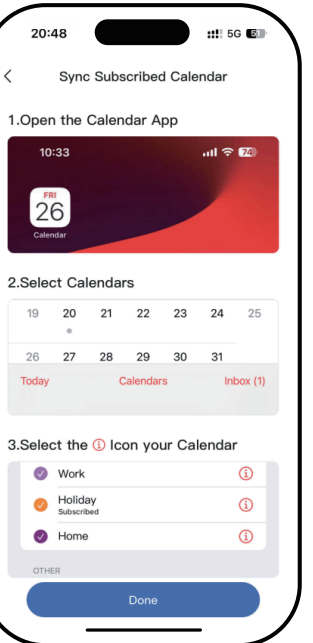
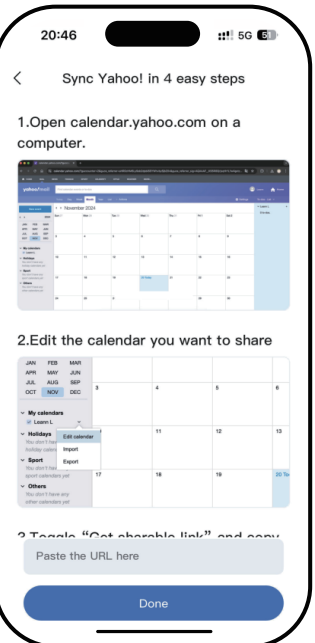
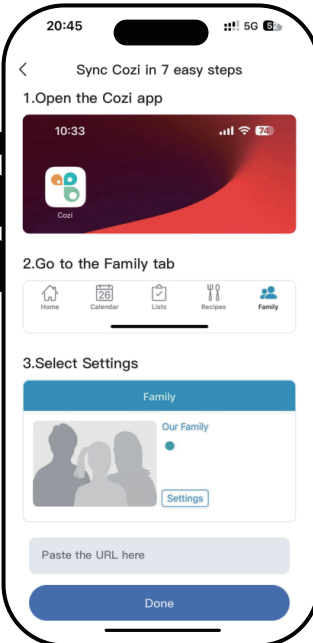
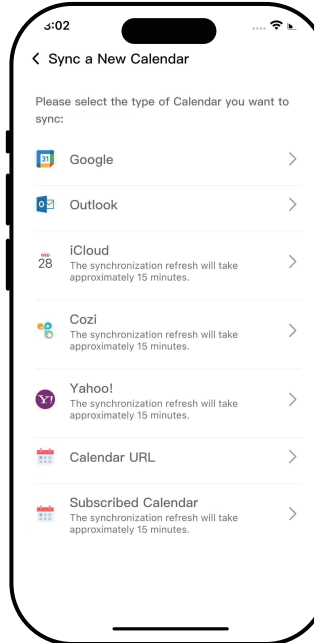

2. Getting Started

2.2.7 Syncing Outlook Calendar

If you're syncing a work calendar that uses Outlook, select Outlook.

1. Choose Two-ways sync or One-way sync as you need.
2. Enter your Email, Phone, or Skype to sign in.
3. Wait downloading your calendar.
4. Choose the calendar you want to sync and press Sync Calendar.
5. Wait for successful upload or back to home.
6. It's done.

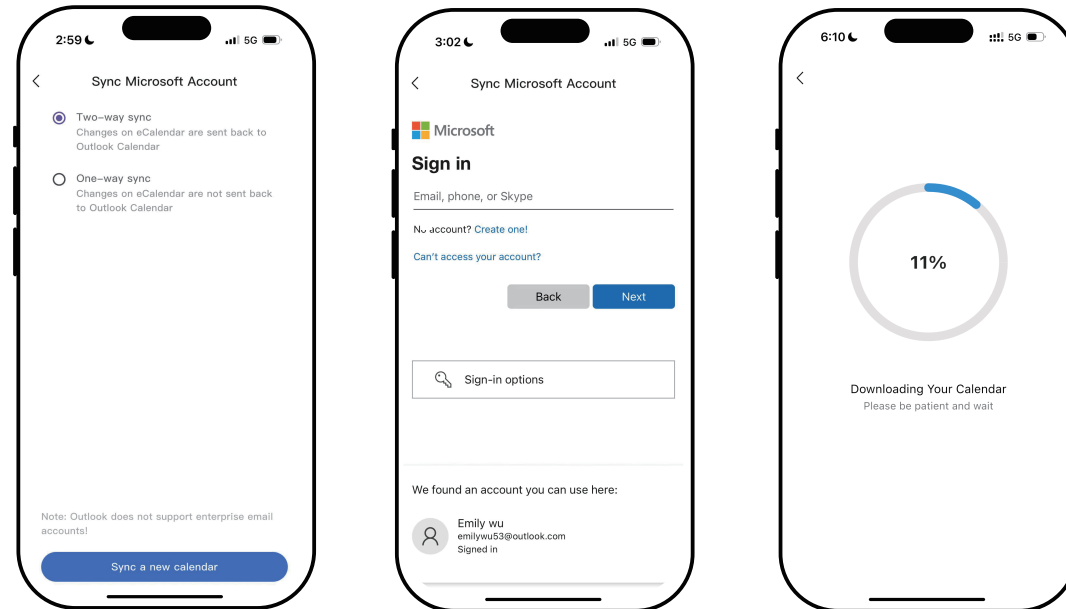

— 27 —

2. Getting Started

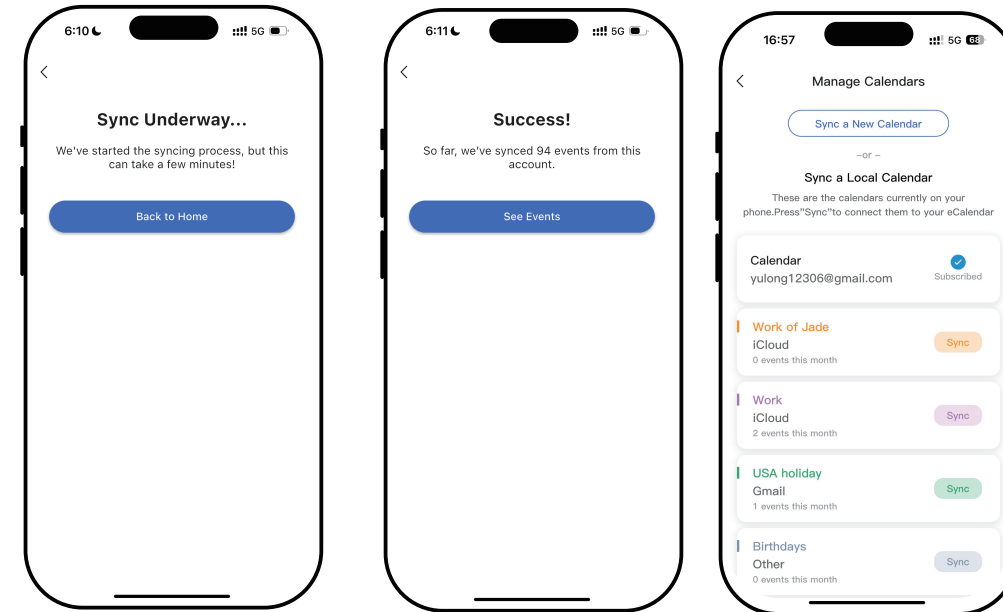

— 28 —

2. Getting Started

Google Event Sync Function Instructions

- Android Devices: After creating a new event in the Google Calendar app, you need to manually tap the "Refresh" button in the sidebar to sync the event to the eCalendar device.
- iPhone: Events are automatically synced to the eCalendar device after creation, with no additional actions required.

Supported Event Types for Google Calendar Sync

- eCalendar supports syncing events only. Tasks are not supported for synchronization at this time.

Time Required for Third-Party Calendar Sync

- Google Calendar and Outlook: Syncing events to the eCalendar device takes approximately 1 minute.
- iCloud, Yahoo, and Cozi: Syncing events to the eCalendar device takes between 1 and 30 minutes, with a minimum of 1 minute and a maximum of 30 minutes.

3. Operation Instruction

3.1 Events

You can view your events in different views on the app or device to suit your needs.

3.1.1 Viewing Events-APP

You can view your events in a Month or Week view. Tap into an event to view details.

Tap  to view events today, depending on the view you're on.

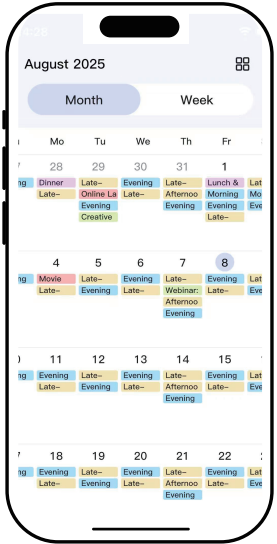

Month View

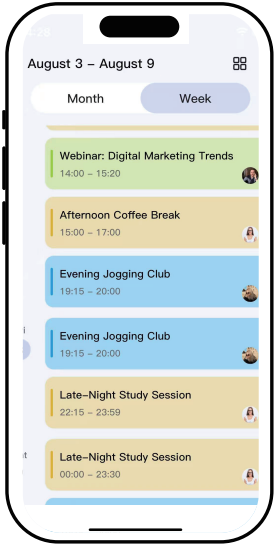

Week View

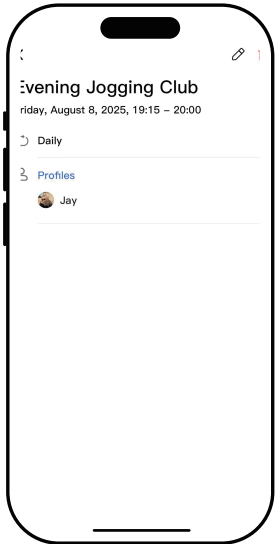

Event Details

3.Operation Instruction

3.1.2 Viewing Events-Device

You can view your events in a Day, a Month, or Schedule view. Schedule view can be configured in Settings  to display between 1 to 7 days.

Tap on an event to view details. You can pinch and zoom to show more or fewer hours in the day.

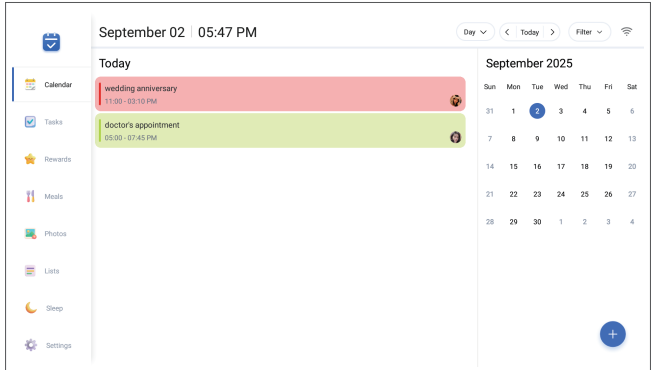

Day View

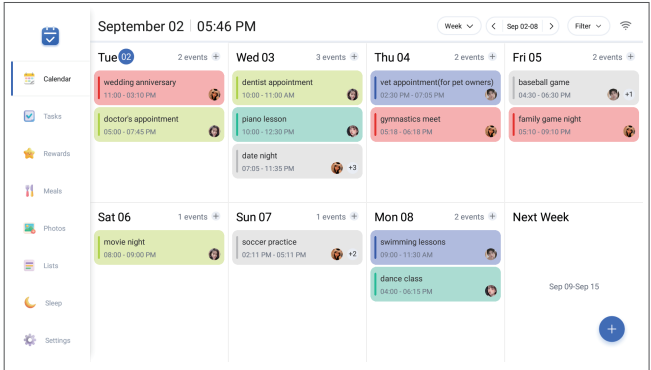

Week View

3.Operation Instruction

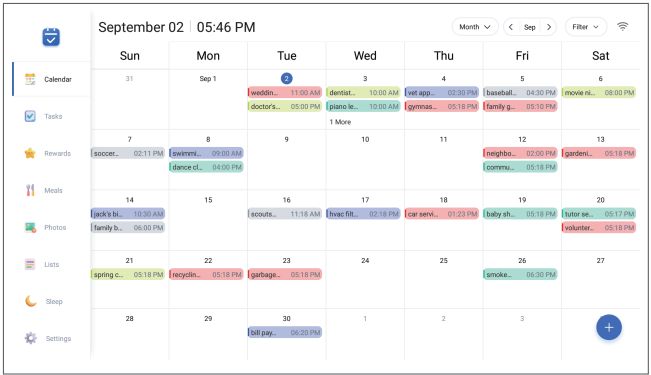

Month View

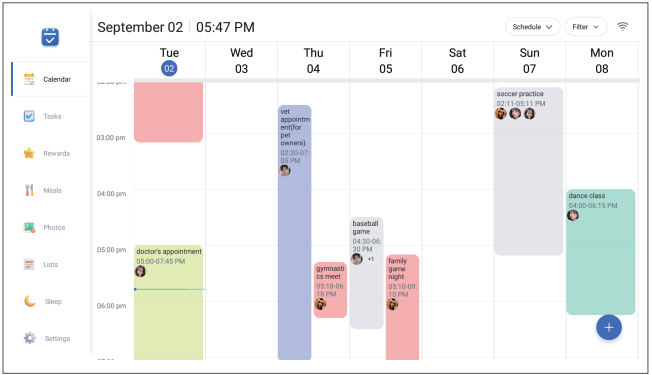

Schedule View

3.Operation Instruction

3.1.3 Creating Events

You can create events on your eCalendar from both the mobile app and the device. Events created on the device will sync to the eCalendar app and vice-versa. If you have synced a Google Calendar with two-way-sync, changes you make with eCalendar will reflect back too.

1. Press the **+** in the bottom right. In Month View, you can press and hold on a date to quickly add an event on that date (not shown).
2. Enter your details and press Save.



1

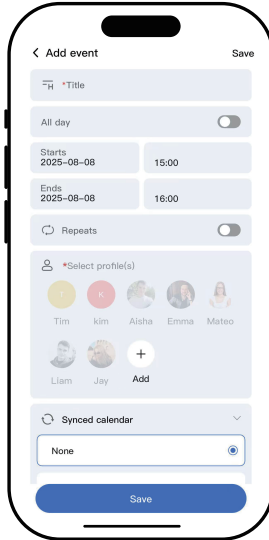

2

3.Operation Instruction

1. Click the plus sign at the bottom or next to the date to create a new event.

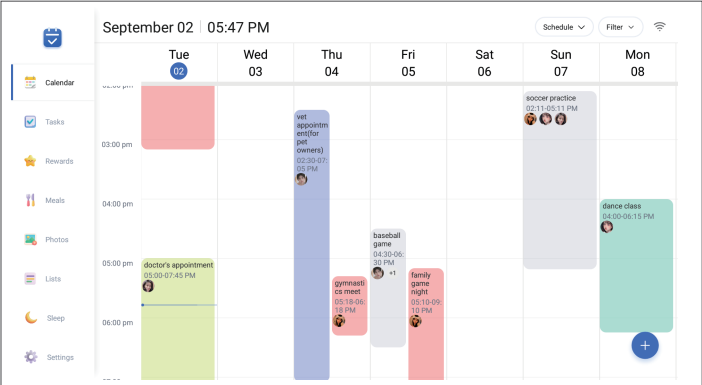

2. Enter your event details and press Save.

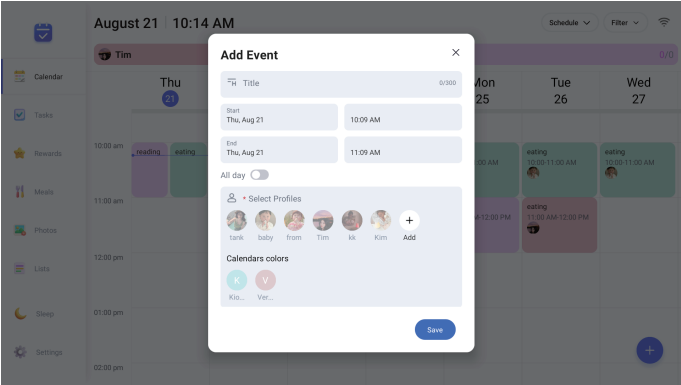

3.1.4 Recurring Events

You can create events that occur on a recurring basis. Events can recur in the following ways:

- Daily
- On certain days of the week (e.g., Tues, Thurs)
- Weekly
- Every X weeks
- Annually

Events can also repeat until a specified end date.

3.Operation Instruction

- 1. Open an Event's details and press Edit.
 - 2. Edit your event details and press Save.
 - 3. If the event is on a 2-way synced Google Calendar, the event changes will appear on your Google Calendar.
- Note for editing Google events: At this time, you can only edit single instances of a recurring event. You cannot convert one-off events into recurring events or edit recurrence rules.

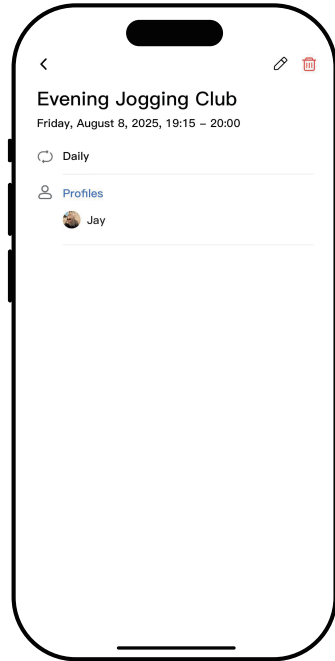

1

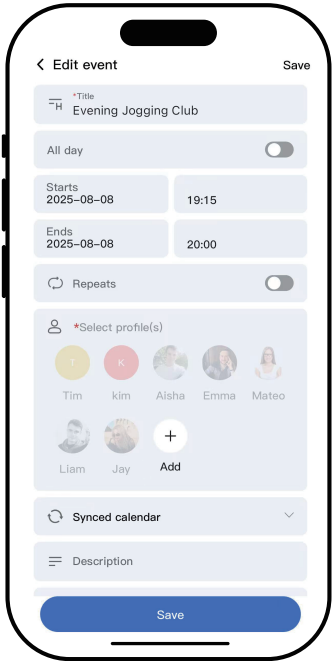

2

3.Operation Instruction

- 4. Once created, you can set notifications in "My Calendar - Notifications - Open Push Notifications".

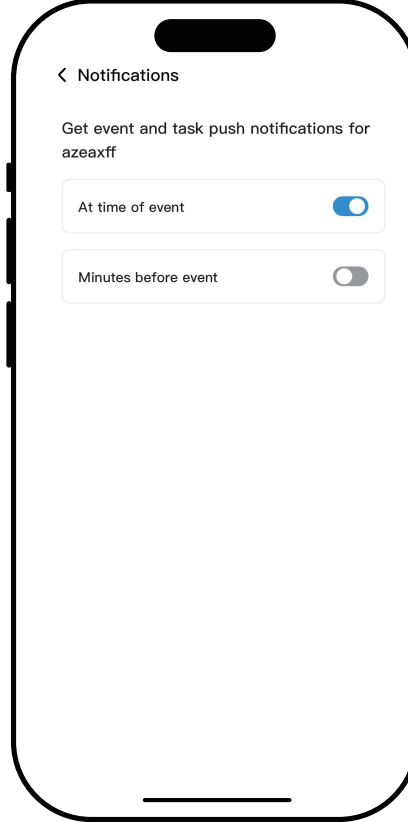
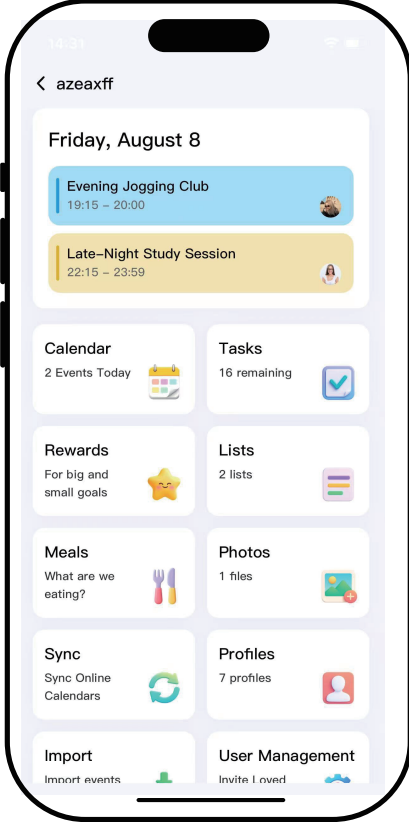

3.Operation Instruction

3.1.5 Edit Event

1. Tap an event to view details and press Edit Event.

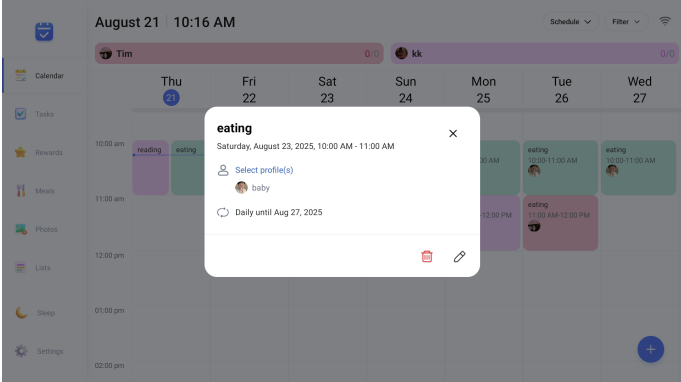

2. Enter your new event details and press Save.

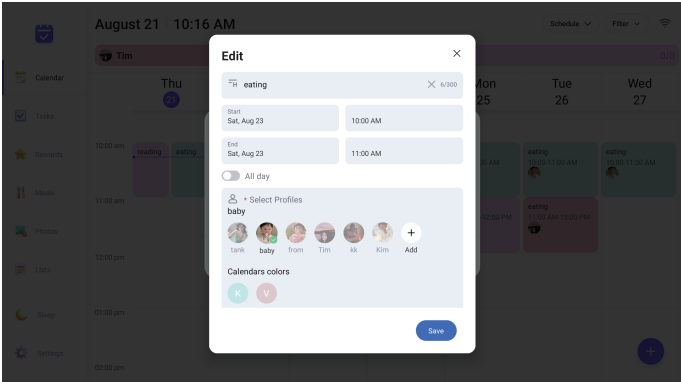

3.Operation Instruction

3.2.1 User management

You can view User management in different views on the app or device to invite registered users to manage the calendar.

1. Using User management-APP

You can click on User Management to invite registered users.

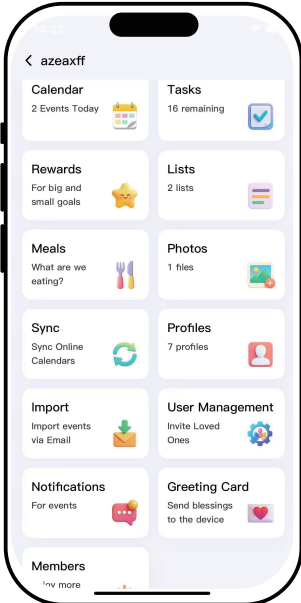

1

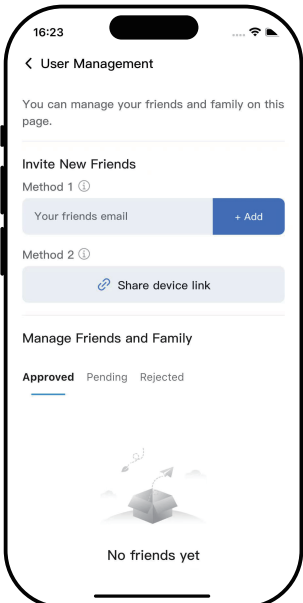

2

3.Operation Instruction

Add the user's email and set one type of permission,The interface for invited users pending decision can be viewed on both the mobile app and the digital calendar device.

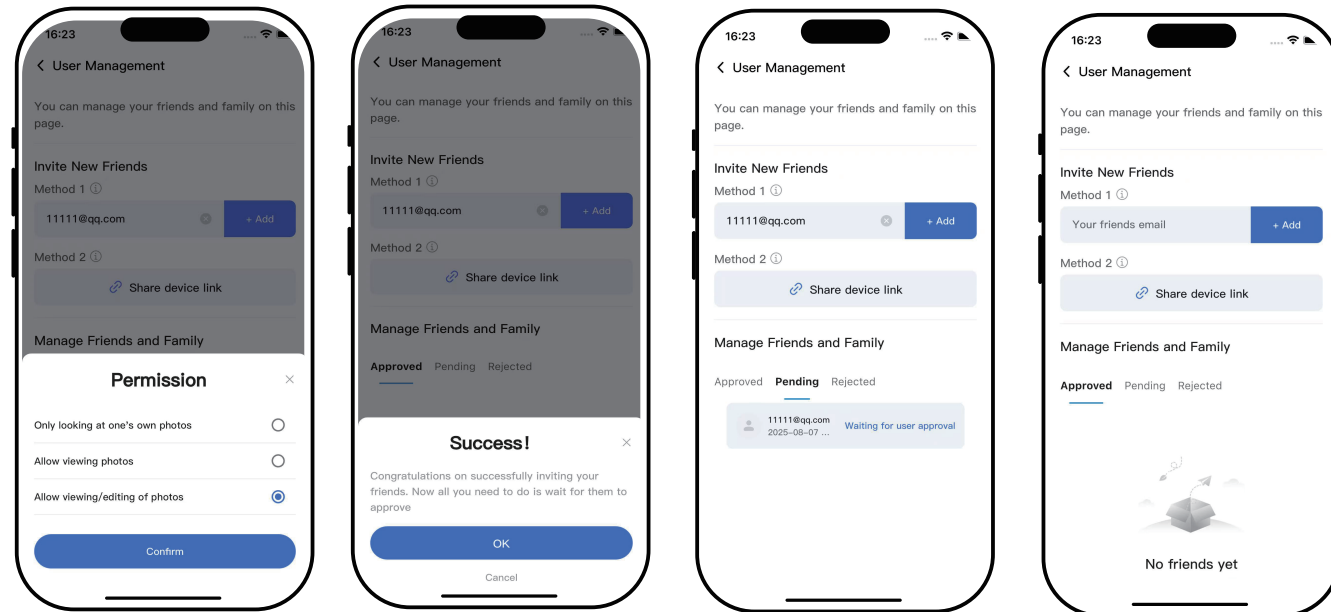

3.Operation Instruction

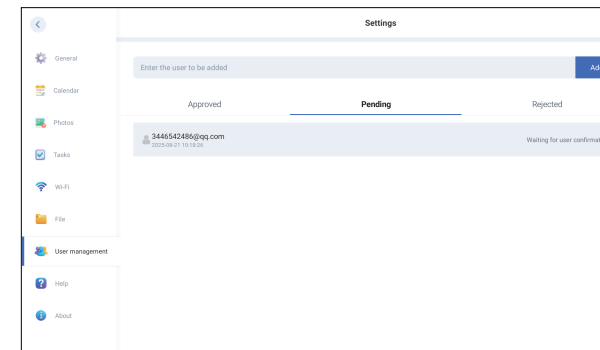

2. Using User management-Device

To invite registered users, you can navigate to User Management.Similar to the mobile app, enter the email of the user you want to invite. If the user is already bound, it will display that this friend is already linked to the device.

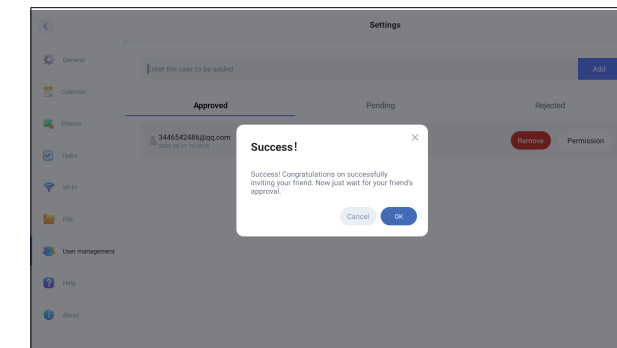
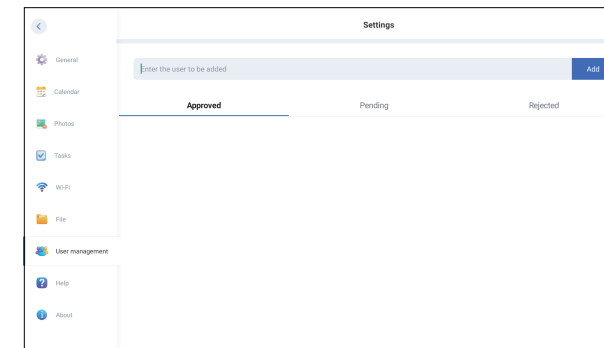

3.Operation Instruction

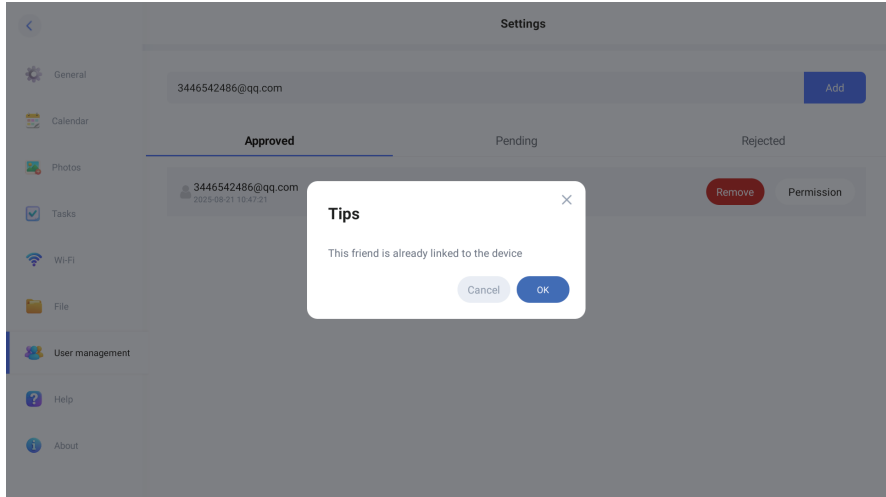

3.Operation Instruction

3. The interface where invited users can view and manage.

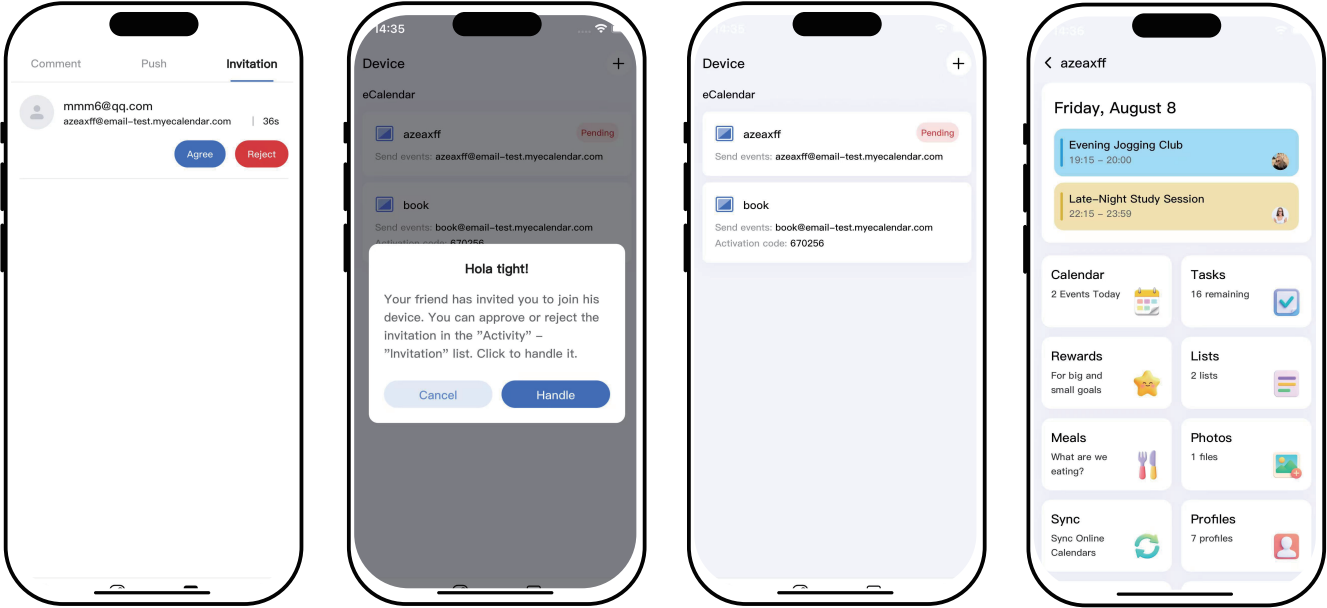

3.Operation Instruction

4. Records of successful invitation interfaces on both mobile and device ends, additionally, the access permissions for invited users can be modified at any time.

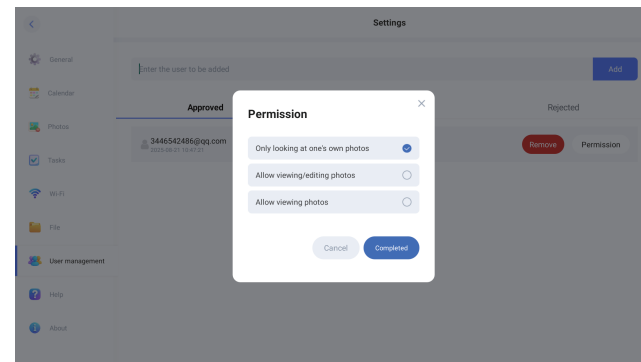
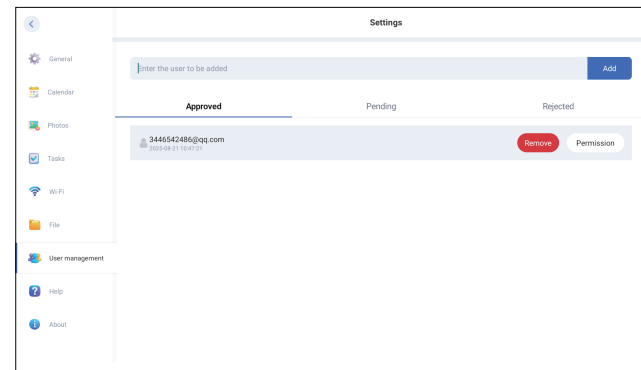
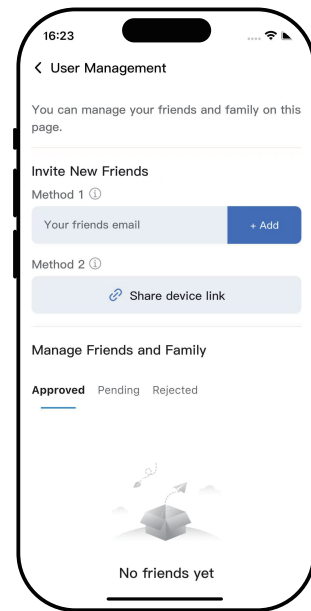

3.Operation Instruction

3.2.2 Create Tasks

The task feature on our calendar photo frame is the perfect way to organize your whole family's responsibilities in one place.

1. Press 'Task'
2. Tap “+” to create a new category
Fill in task information & tap save
3. Click on a saved Chore to edit and delete it.

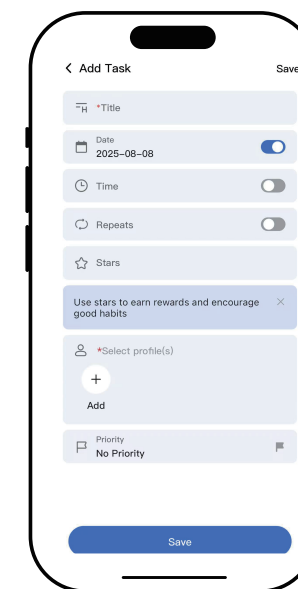
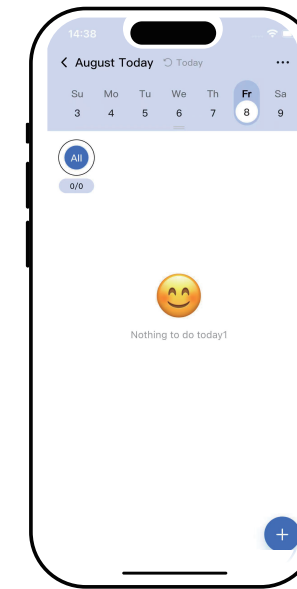
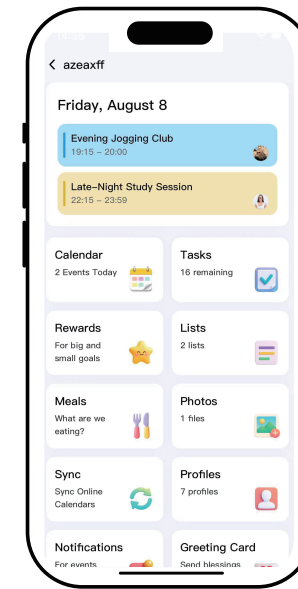

3.Operation Instruction



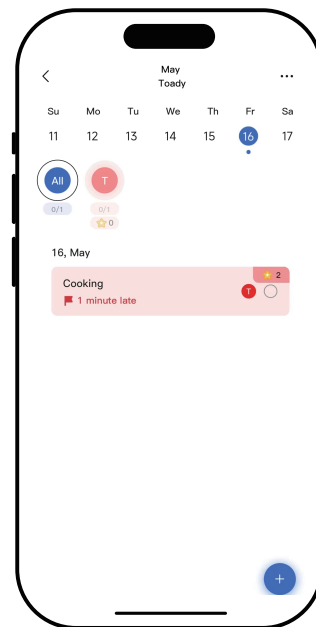

3



3

3.Operation Instruction

4..Tap the saved task, support click  to edit the task, 5. Tap  to do profile setting or display setting click  to delete the task,click mark as complete to complete the Task.

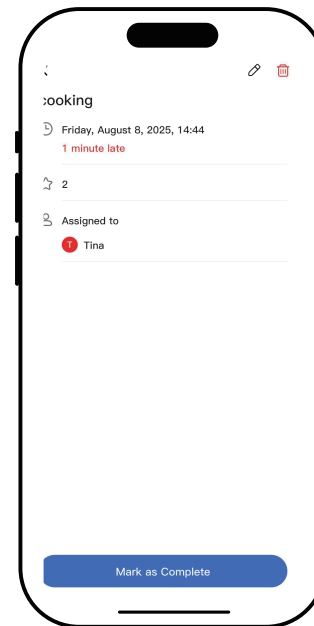

4

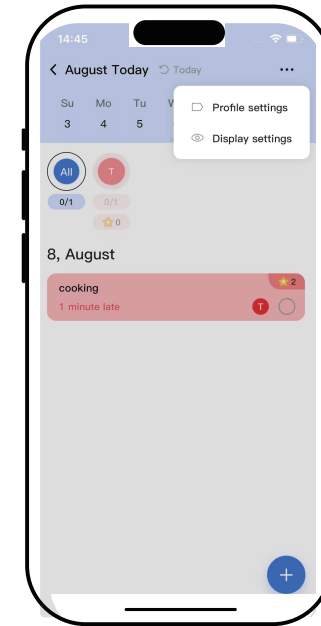

5

3.Operation Instruction

3.2.2 Create Tasks

1. Press the “+” in the bottom right of the Task screen to add a new task.

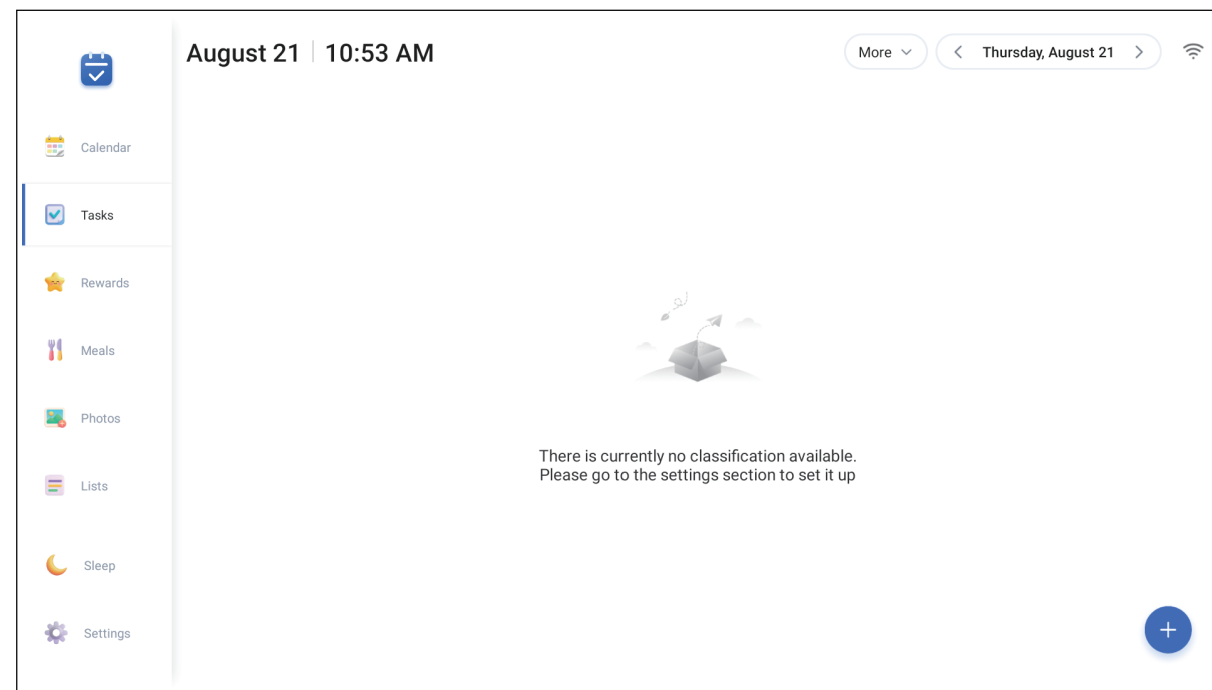

3.Operation Instruction

- 2.Fill in task information
Required fields: Title & Profile

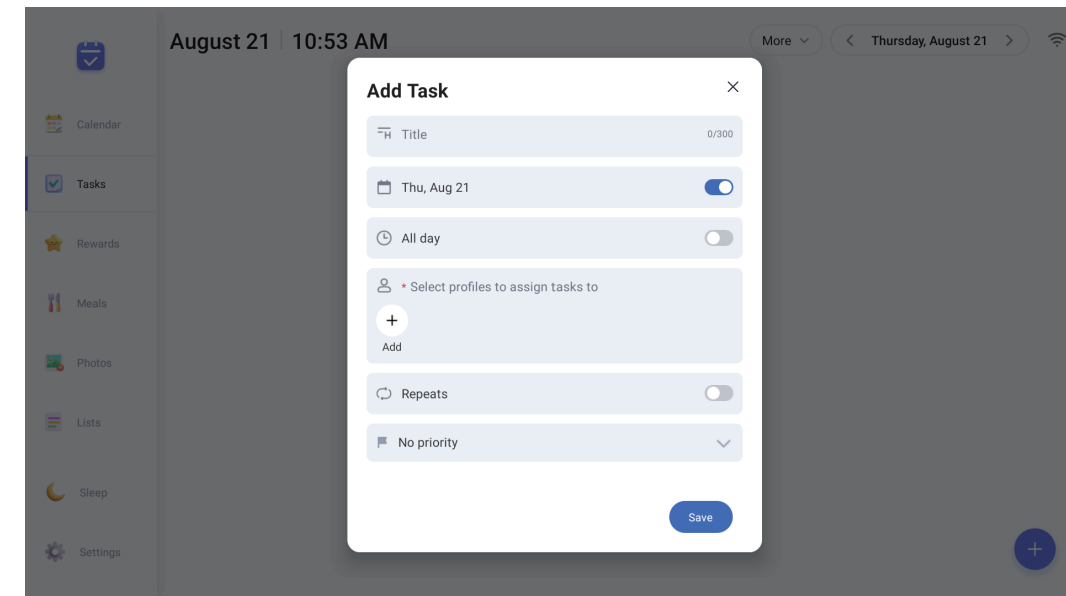

3.Operation Instruction

3.Press 'Save' to create your task.

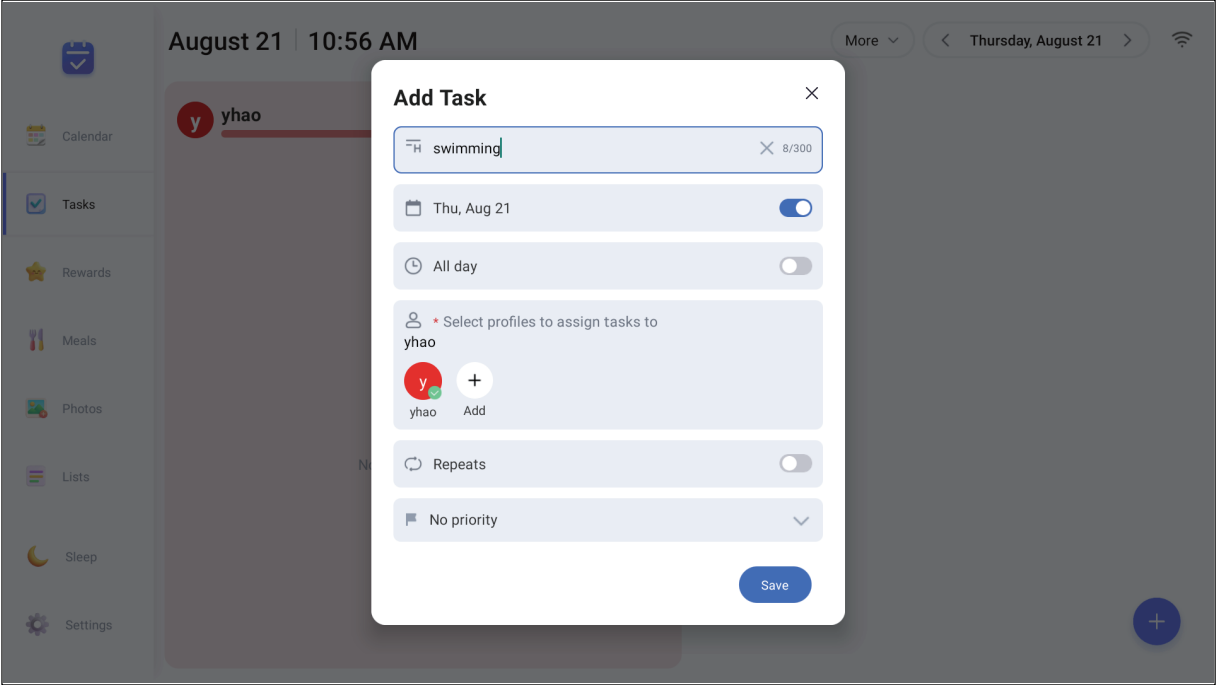

3.Operation Instruction

4.Tap the Task, support click  to edit the task,click  to delete the task,click Mark as complete to mark complete the Task

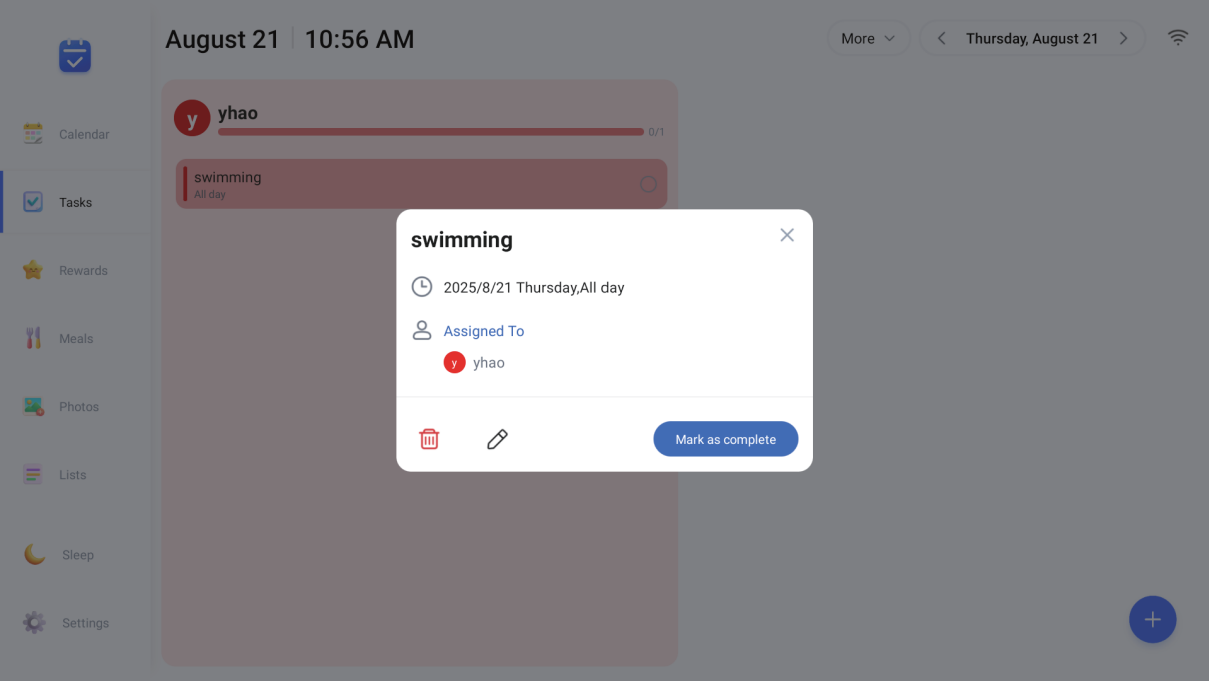

3.Operation Instruction

5. Tap more to do basic setting & category(profile) setting

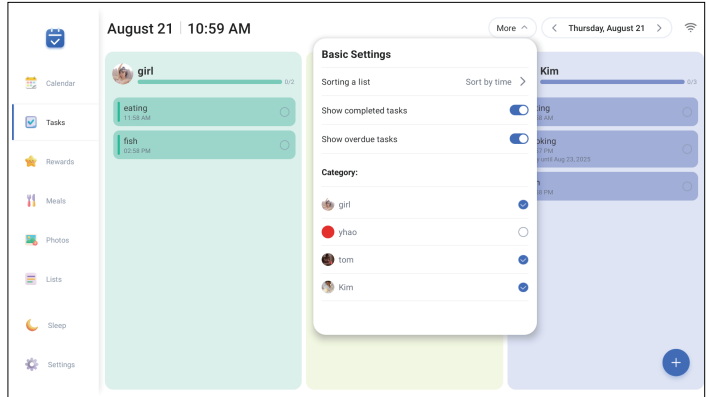

6. Tap the circle behind the task and check it to mark the completion of the task.

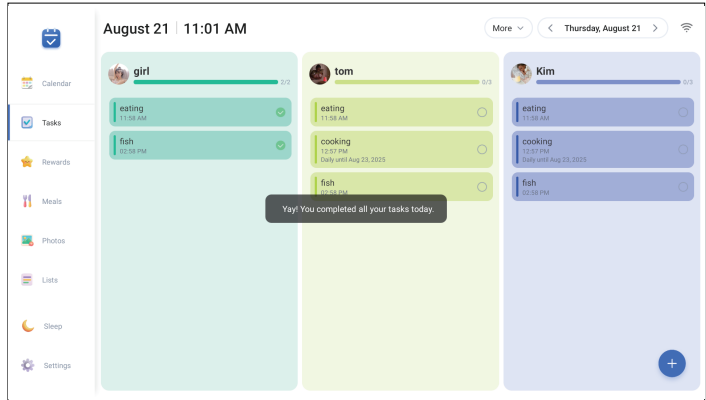

3.Operation Instruction

3.3 Rewards

- Tips:
- 1.Task reward creation is exclusive to the mobile app. The device interface only supports viewing and redeeming rewards.
 - 2.If you have not previously created tasks using the Task feature, a Profile must be established before initial use of the Reward function.
- Required steps:

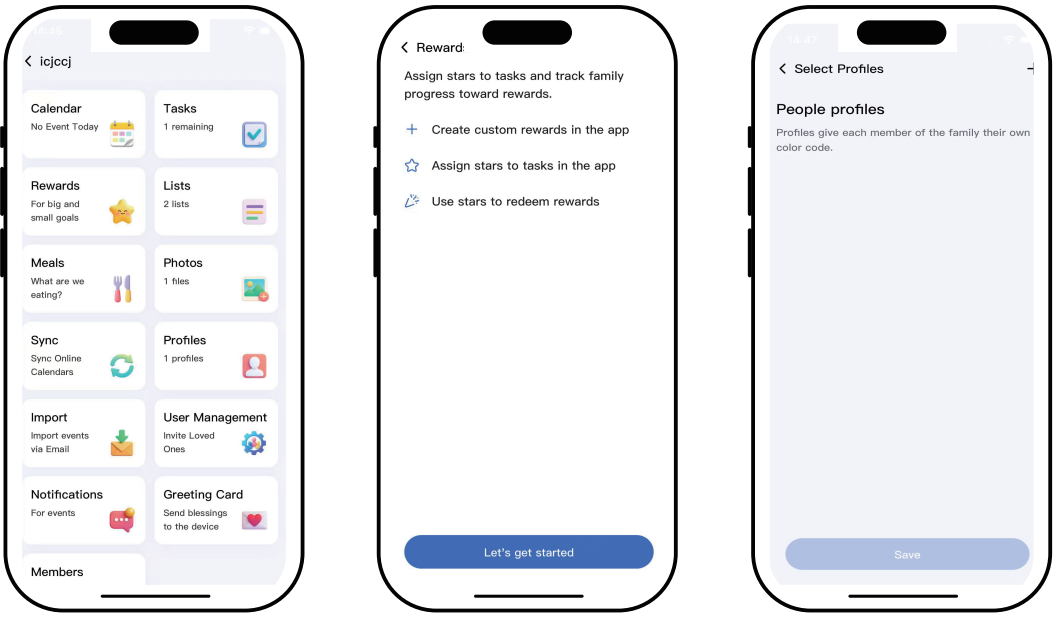

3.Operation Instruction

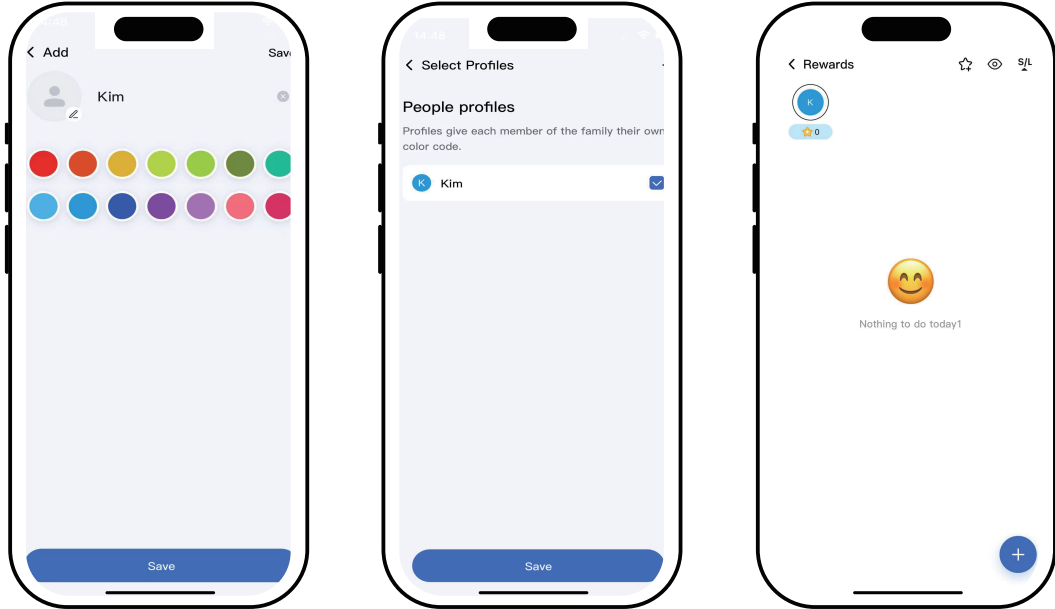

3.Operation Instruction

3.3.1 Add Rewards

1. Click the plus sign  at the lower right corner.
2. Fill in the Reward Name and Description, choose an Emoji, choose whether to Renew after redeeming, specify the Star Cost, and finalize by selecting the Target Profile.
3. After completing all fields, click Save.

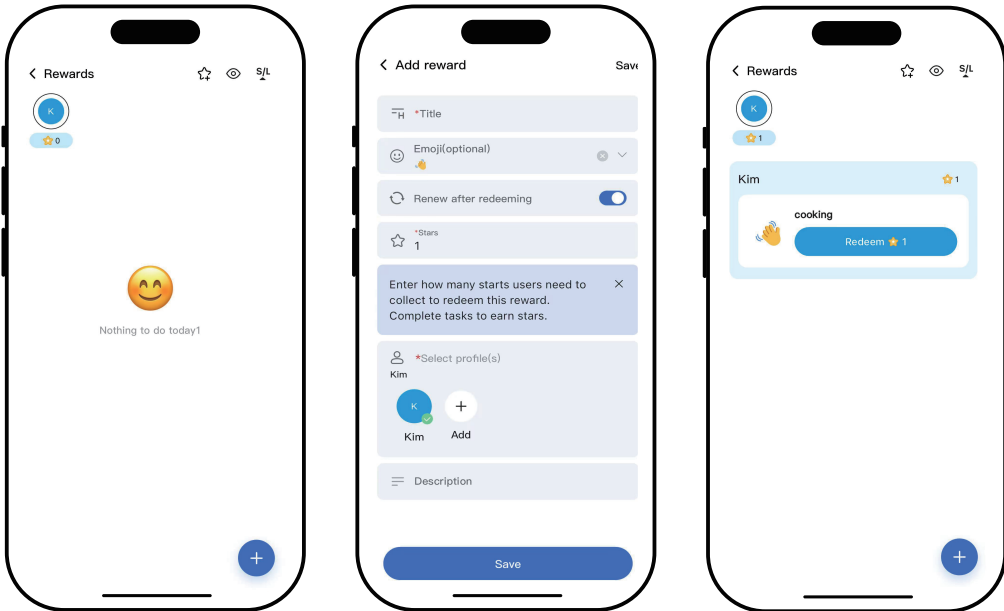

3.Operation Instruction

3.3.2 Give Stars

- 1.Click on the "Give Stars" in the upper left corner.
- 2.Select profiles and input number, then tap Confirm.

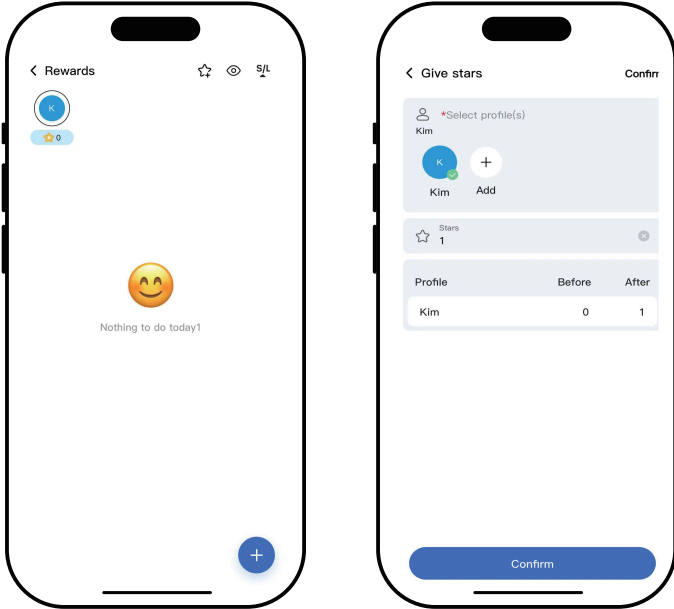

3.Operation Instruction

3.3.3 Redeem Reward

- 1.Tap the "Redeem" button
- 2. Done An animated confirmation prompt will appear. Select "Done" to finalize your redemption.
- 3. Upon successful redemption, the transaction record will be automatically displayed.
- 4. Content Adjustment: Tap the redemption icon,Modify the relevant content in the editing interface.

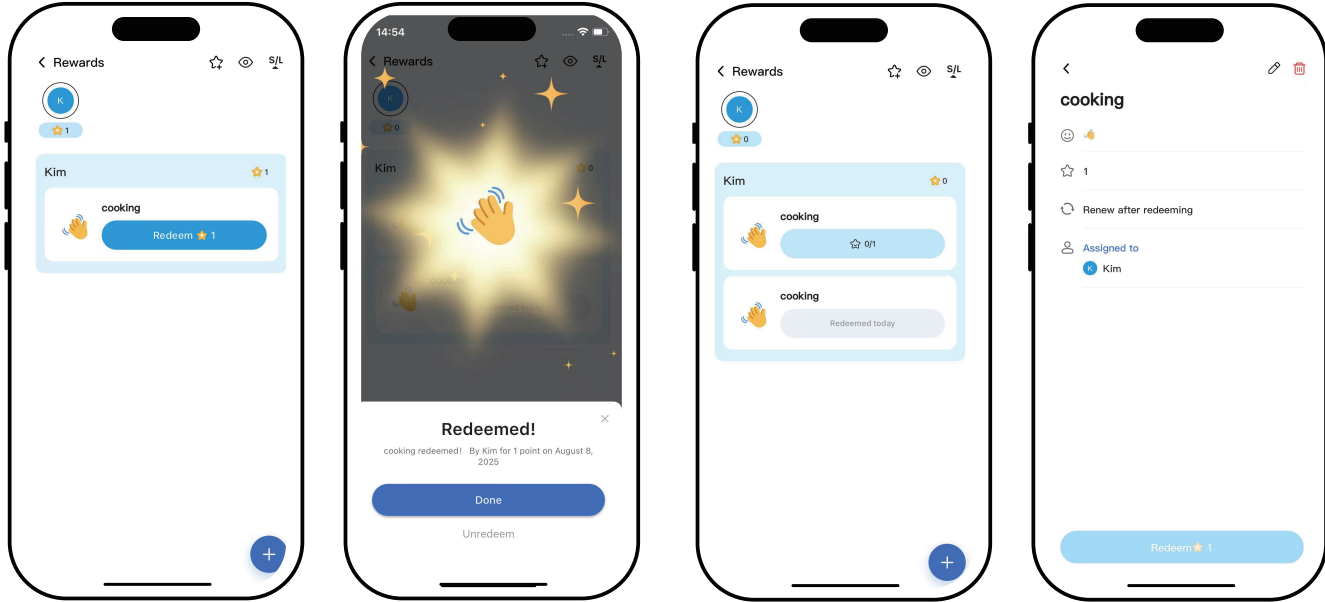

3.Operation Instruction

3.3.3 Redeem Reward

Option to hide redeemed rewards information.

3.3.4 Hide Redeemed Reward

3.3.5 Sorting

Sort rewards by point value in ascending/descending order.

3.Operation Instruction

3.4 Meals

3.4.1 Create Meal plans

① Click "Meals"

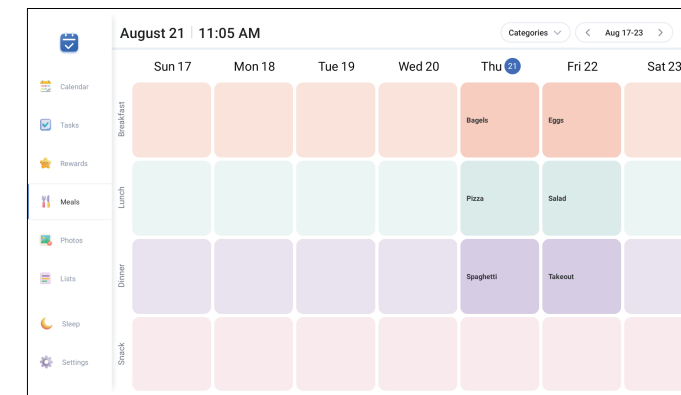

② Click on the breakfast/lunch/dinner/dessert option under the date and select the desired meal.

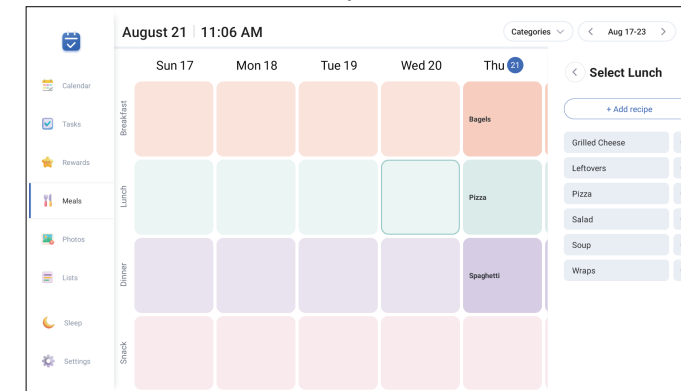

3.Operation Instruction

③ After completing the arrangement, it can be synchronized to the mobile interface.

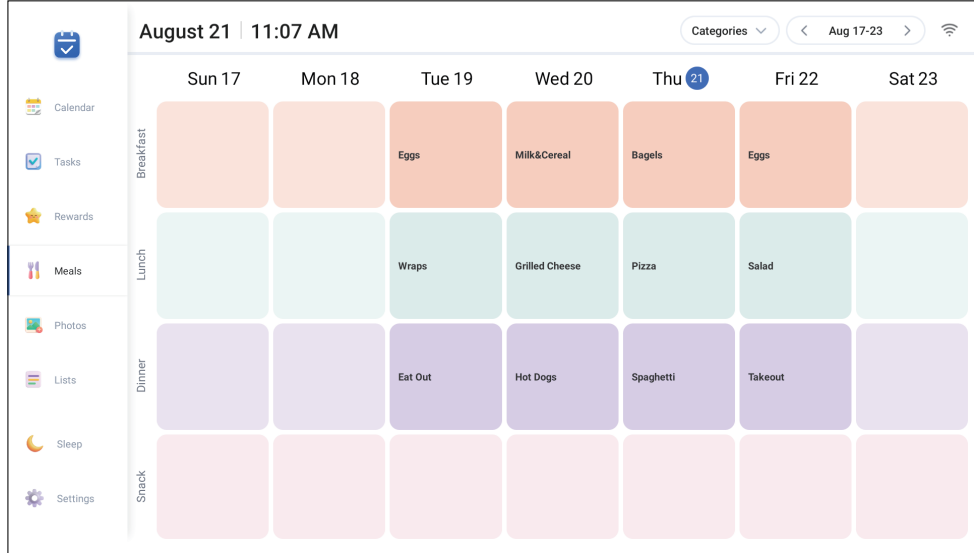

3.Operation Instruction

3.4.2 Add/delete/edit dishes/plan on the device

- ④ Long press on breakfast/lunch/dinner/dessert under date ,then click "add recipe"
- ⑤ Clicking ... after the dish, can edit dish names, select table of contents, make dish introductions, and save.

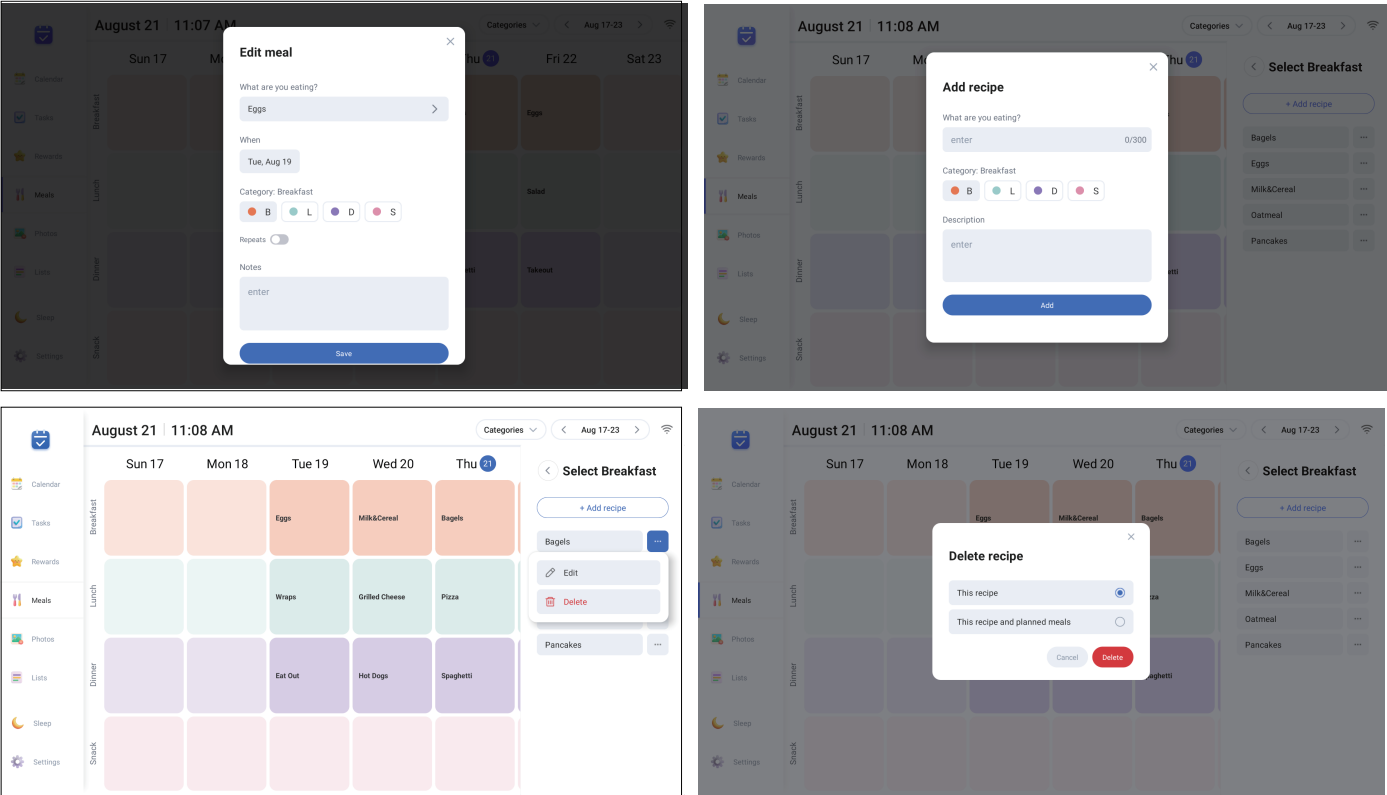

3.Operation Instruction

⑥ Type the dishes on what are we eating, select the corresponding breakfast, lunch, dinner, dessert catalogs, and also support provide dish introductions. Open the repeat button, select the number of times and repeat deadline. Click Save to complete dish creation and planning.

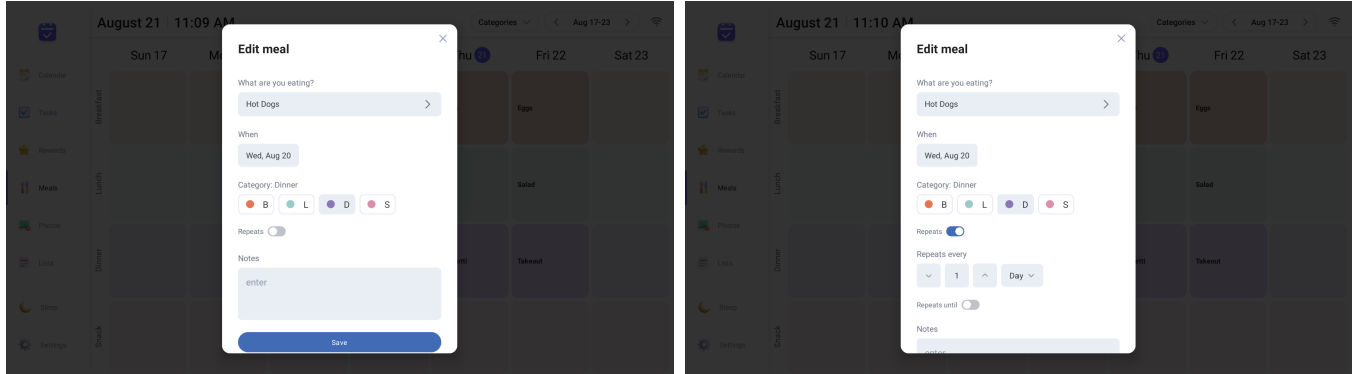

⑦ Tap on the dishes on the pre-set plan to click edit. Edit the dish names to set duplicates, make dish introductions, or click the delete button to delete the plan.

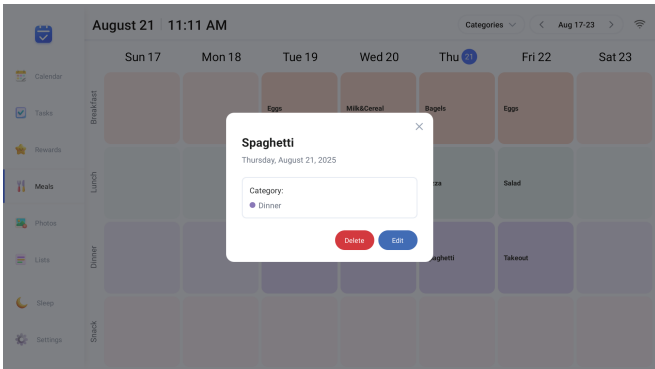

3.Operation Instruction

3.4.3 Create new dining plans on app:

① Click on the main interface Meals.



3.Operation Instruction

- ② Long press the breakfast/lunch/dinner/dessert option under the date and select the desired meal. Click the+ in the bottom right corner.
- ③ After completing the arrangement, it can be synchronized to the device interface.

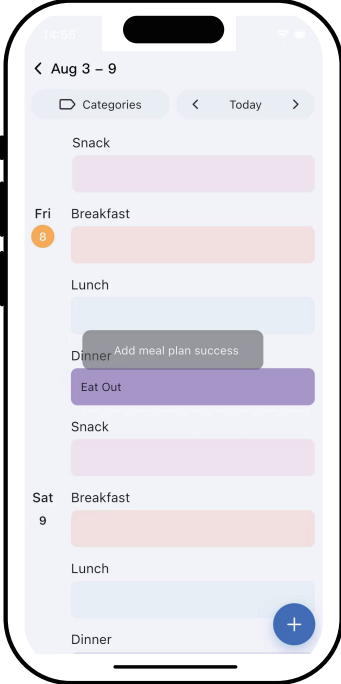
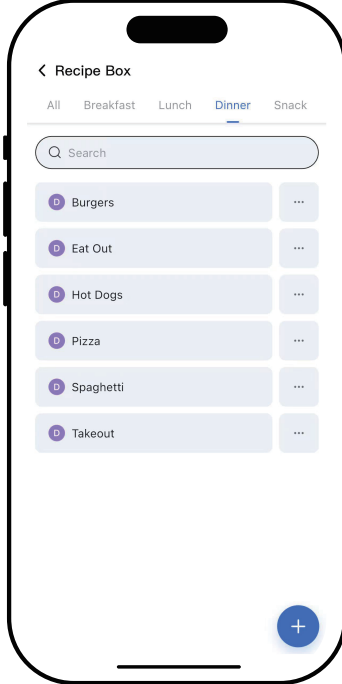

3.Operation Instruction

3.4.4 Delete and edit dishes on app

- ④ Click the+ in the bottom right corner of the Meals interface to enter the receipt box.
- ⑤ Click ...on the right of the created dish to Edit or delete dishes.

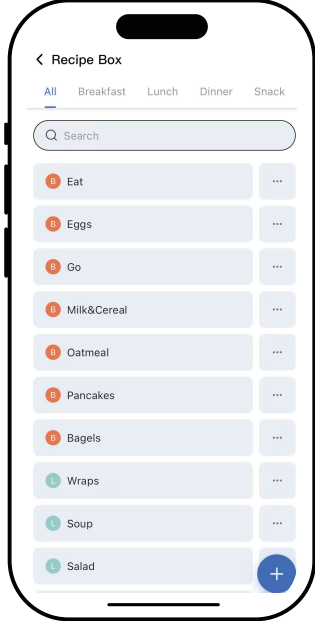

④

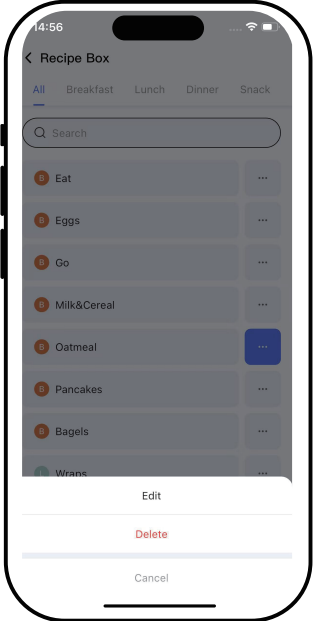

⑤ -1

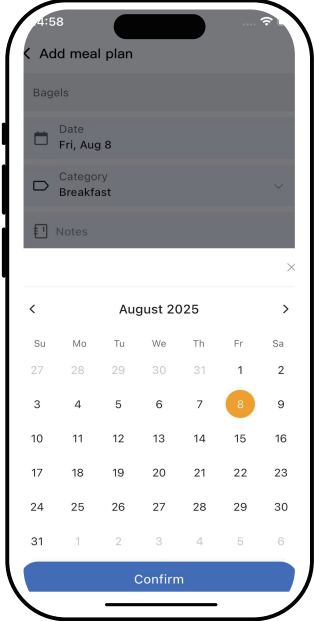

⑤ -2

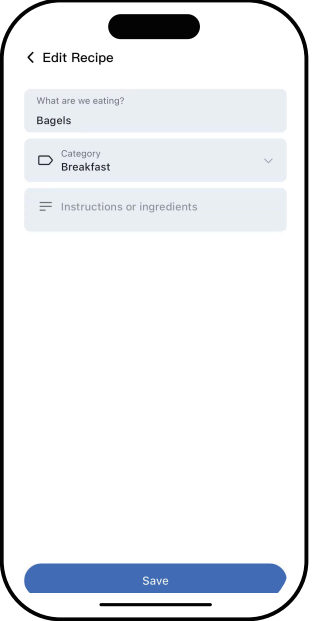

⑤ -3

3.Operation Instruction

⑥ Click on the bottom right corner and add the desired dish, support to edit the dishes, select the corresponding breakfast, lunch, dinner, dessert category, and also provide dish introductions, Click "save".

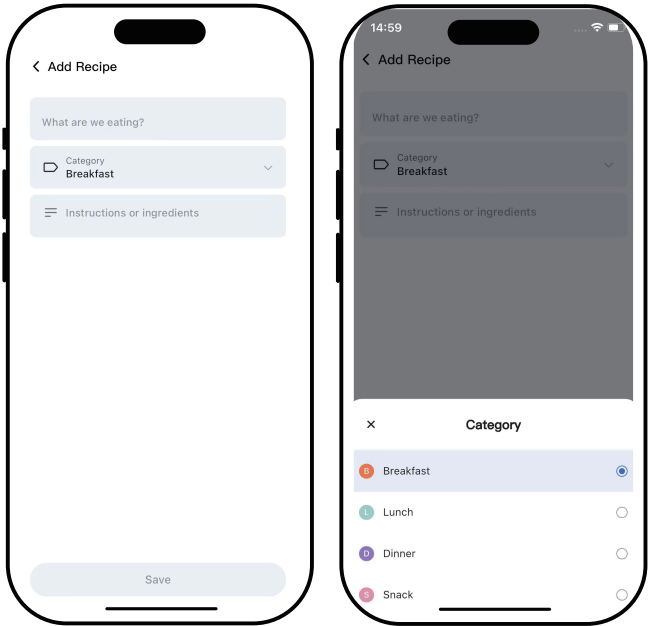

⑦ On the Meals interface, tap on the pre-set dishes and click Edit to edit the dish names, set duplicates, rotate the table of contents, or click the delete button to delete the plan.

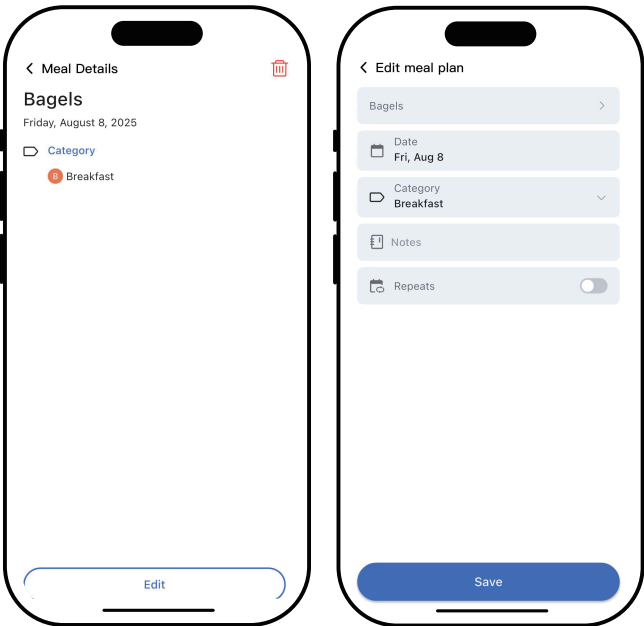

3.Operation Instruction

3.4.5 Hiding and editing Category (same operation on mobile and device)

① Click category on Meals.

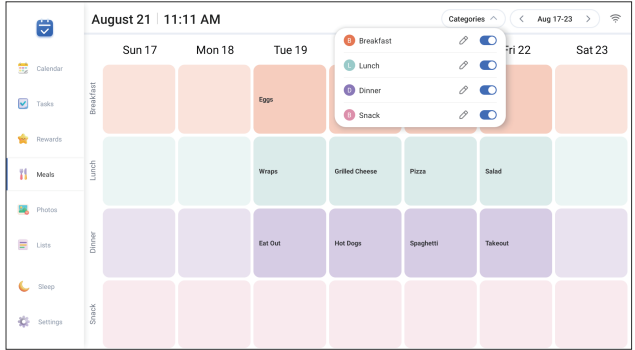

② Click the switch button for breakfast, lunch, dinner /dessert to choose whether to display these directories.

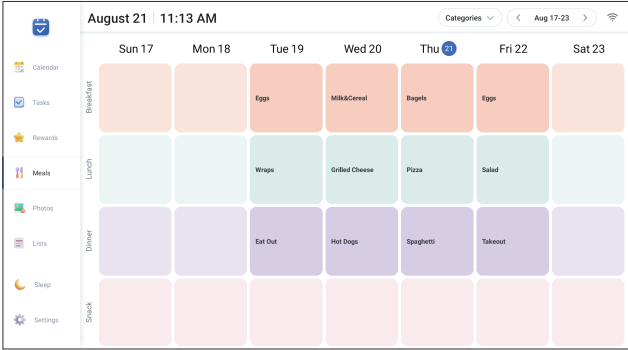

③ Click on the edit icon to edit the category name and select the color, Click save to finish edit.

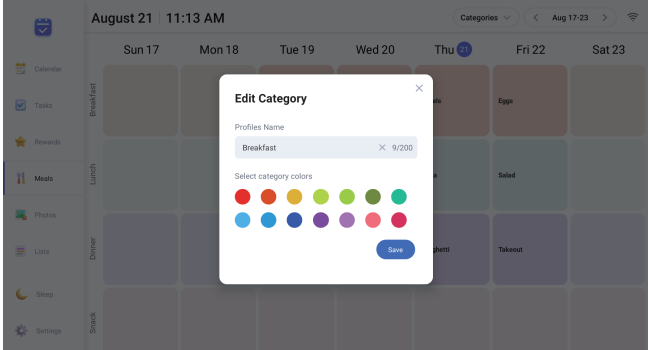
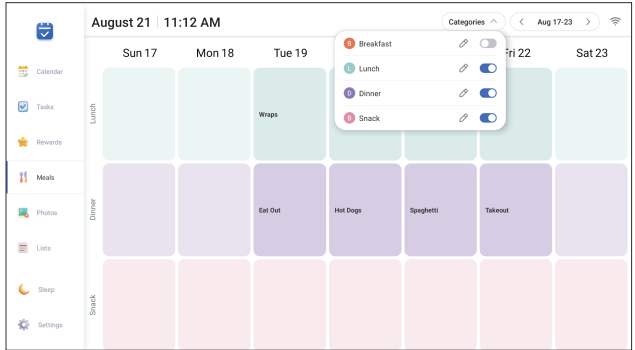

3.Operation Instruction

3.5 Photo & Video

The photo album supports uploading pictures and videos, and allows multiple people to share.

3.5.1 Photo & Video-App

You can upload your pictures or videos using the app's photo function.

1.Click  on left page or Photos on right page.

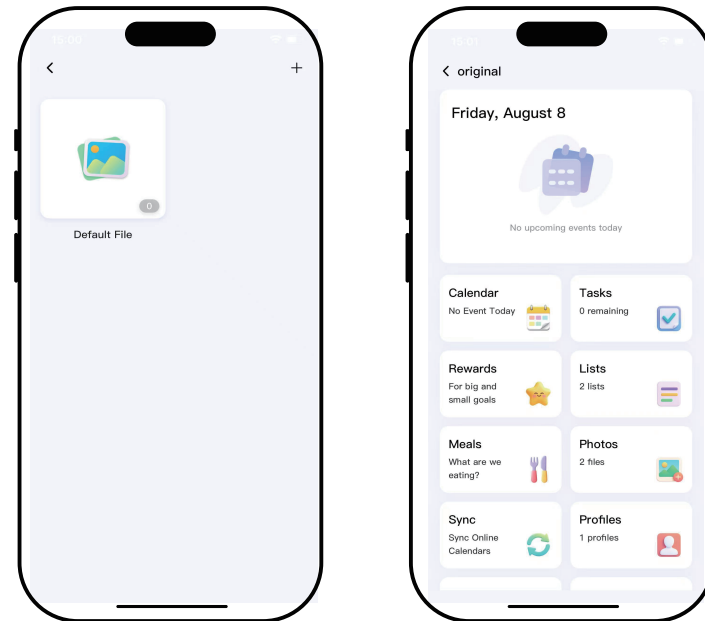

3.Operation Instruction

2. Click "+" to create a new folder.
3. Click the "default file" or the folder your created, tap "+"
4. Select Album to choose photos&videos or Camera to take photo or videos.

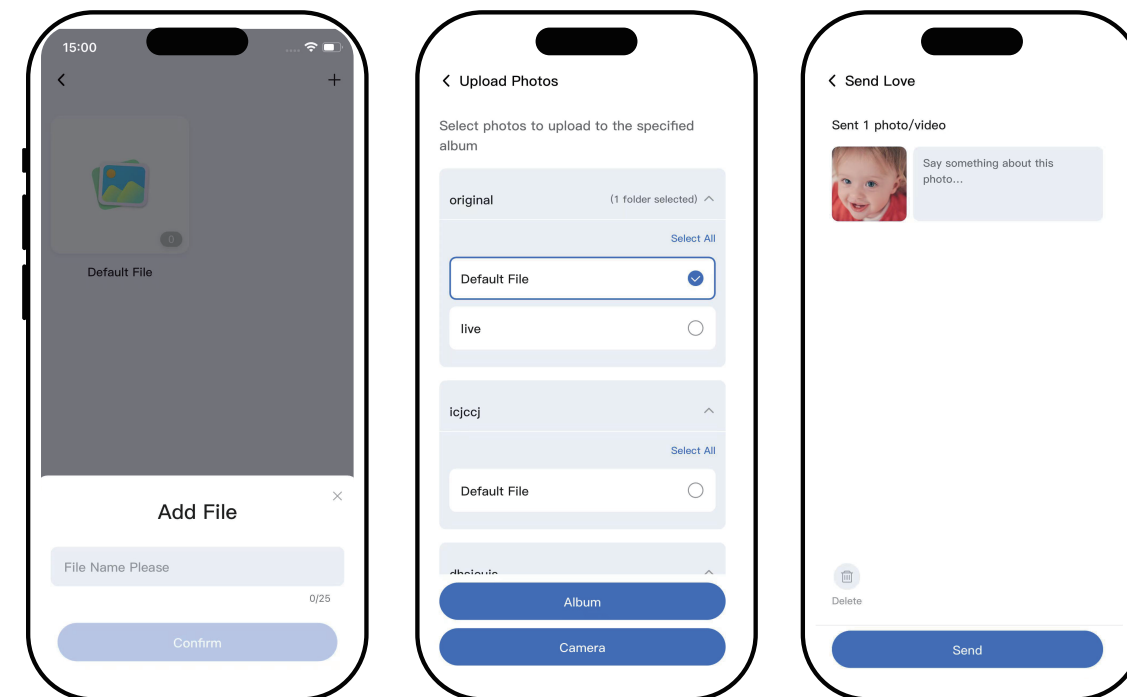

3.Operation Instruction

- 5.Click the button in the upper right corner, and you can delete the photos you are uploading.
- 6.The device currently does not support uploading photos or videos larger than 200MB.

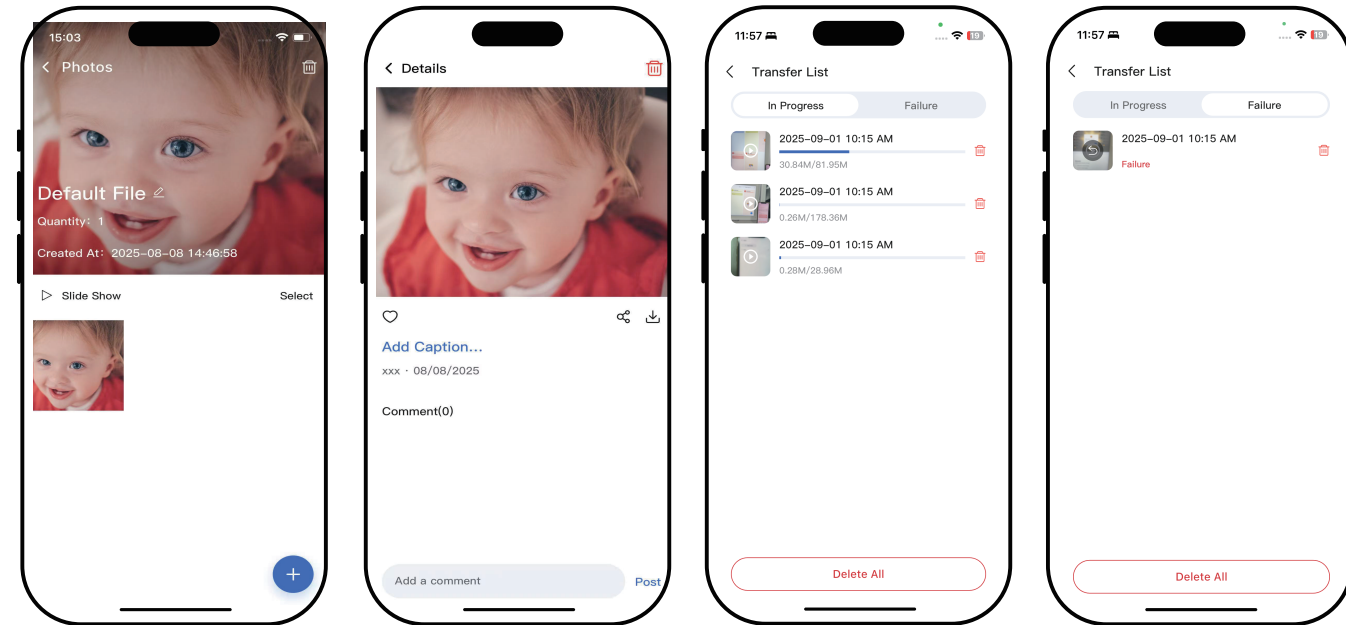

3.Operation Instruction

3.5.2 Photo & Video-Device

1. Photo albums can display the pictures or videos uploaded from our phones.
2. Create folders and mark pictures or videos as favorites.
3. Click on an uploaded image or video to edit it.

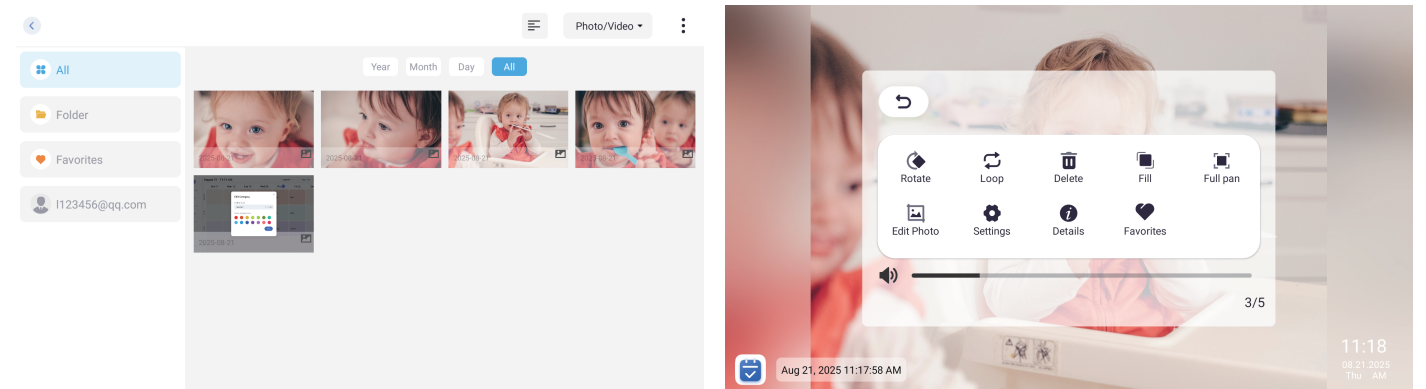

3.Operation Instruction

3.6 Lists

The lists sync between your eCalendar and the mobile app, keeping the whole family on the same page. You can create as many lists as you like.

3.6.1 Lists-App

Creating and Editing Lists

1. Open the Lists on the calendar home screen.
2. Press "+" "New List" in the top right corner.
3. Name your list, choose a color, then press "Save."
4. Your new list is ready.
5. Tap the list to add items.
6. Press the list, then tap the "... " in the upper right corner to edit or delete it.
7. Tap the circle next to an item to mark it as completed; the item will then disappear.
8. Tap the "Show completed items" icon at the bottom to view completed items.

3.Operation Instruction

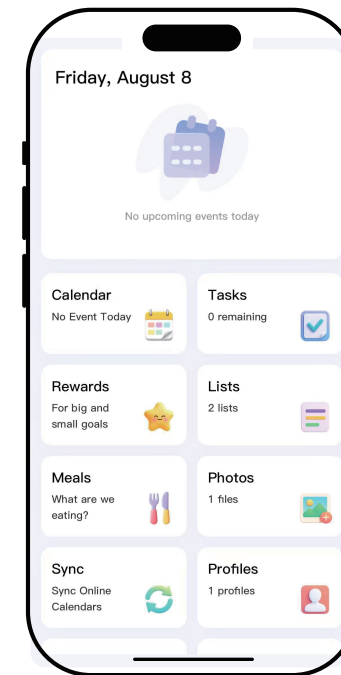

1



2

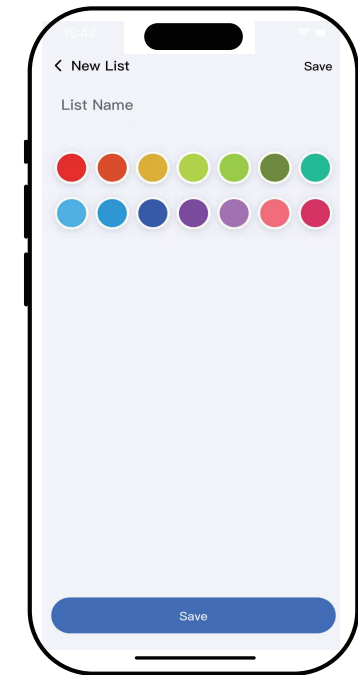

3

3.Operation Instruction

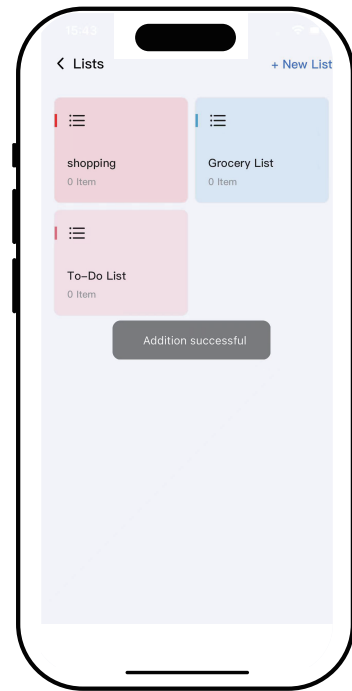

4

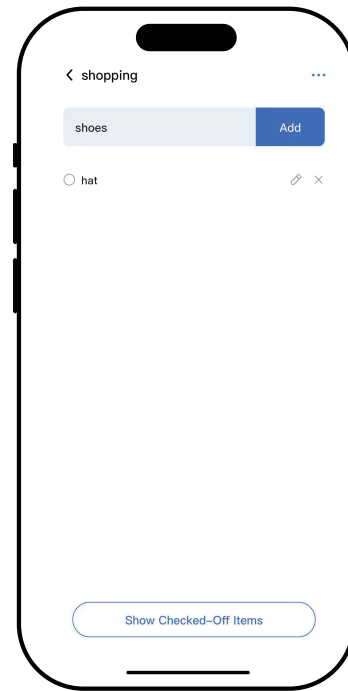

5



6

3.Operation Instruction



7

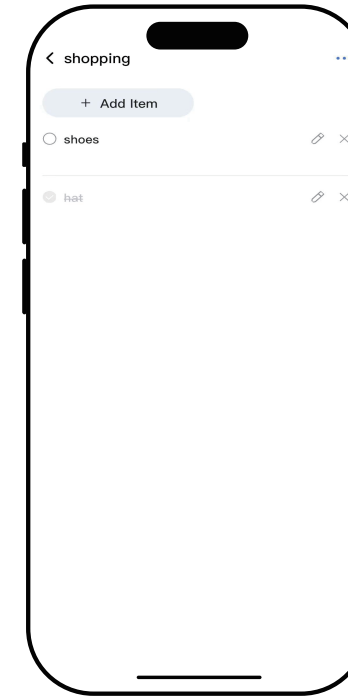

8

3.Operation Instruction

3.6.2 Lists-Device

1. Tap the Lists icon in the sidebar to open the lists.
2. Tap the arrow next to the list name, such as "Shopping List".
3. Press "+New List", enter the new list name, choose a color, and select the list type.
4. Tap a list to add items.

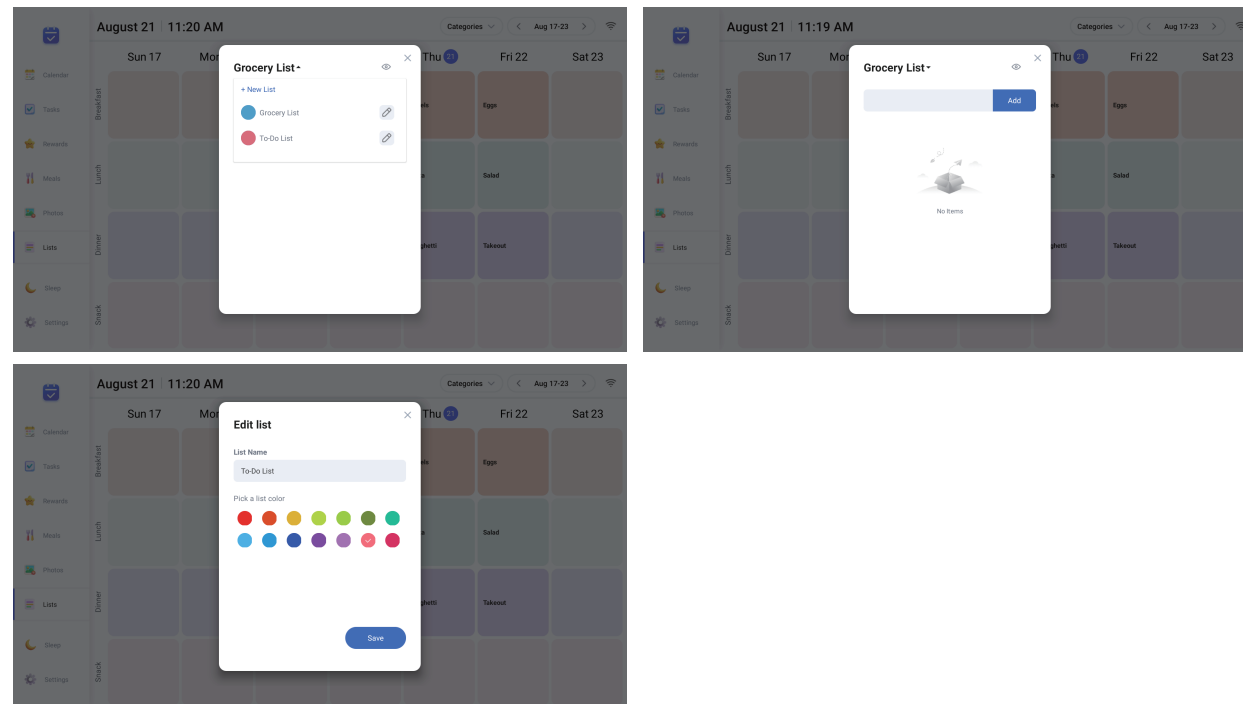

3.Operation Instruction

3.7 Profiles

Organize events and tasks for your family members by using Profiles.

- Events
- Add profiles to events to show who's attending.

Device-Profile

1.Event-Profiles

Manage profiles via Filter > Event Profiles.

(Note: Deleting profiles is disabled on the device. You can only add new profiles or modify existing ones.)

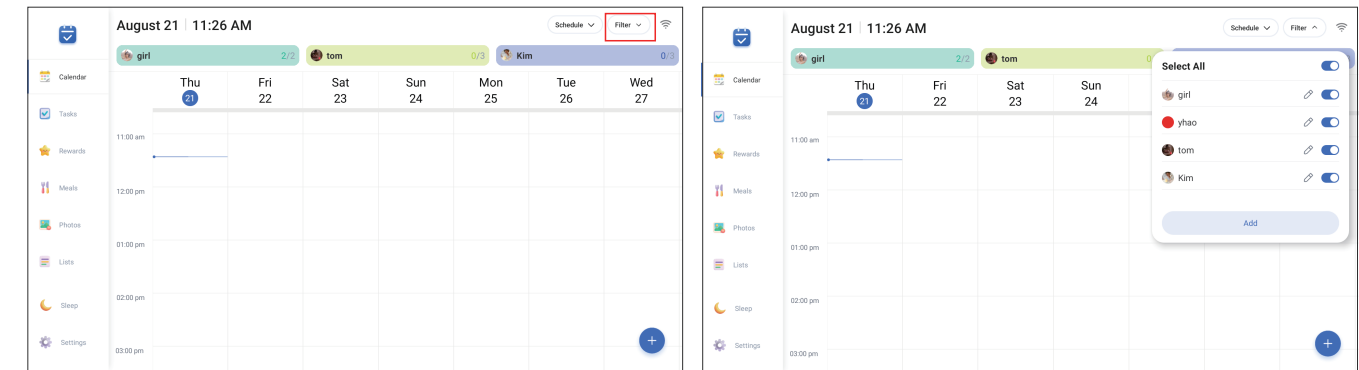

3.Operation Instruction

2.Show/Hide Profile Events

Toggle the switch  to instantly show or hide all schedules linked to this Profile.

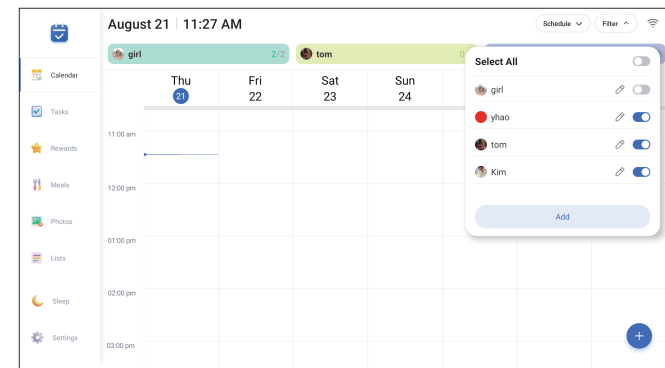

3.Edit Existing Profile

Tap the Edit icon () to customize profile details like name, color, and display preferences.

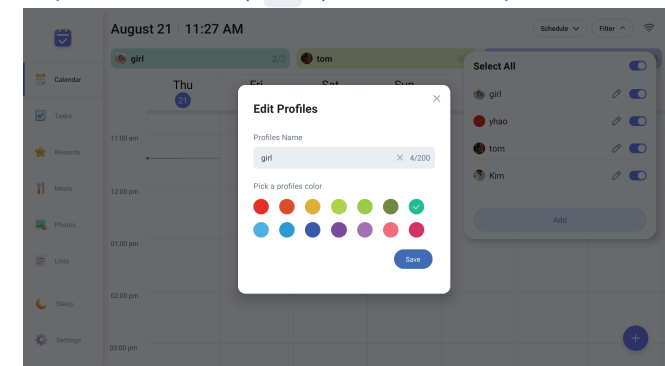

3.Operation Instruction

4.Create New Profile

Tap +Add → Build custom profiles (e.g., work, fitness, travel) to organize events by category.

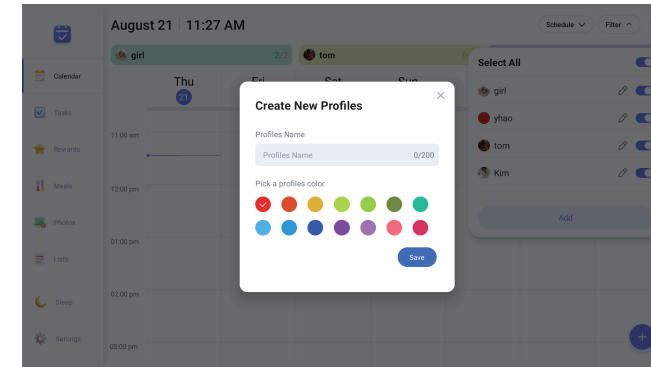

• tasks

Add profiles to tasks to assign household responsibilities.

3.7.1 Add Profiles

1. On the homepage, click on "Profiles".
2. The first time you use it, a usage tip will pop up.
3. Tap "Add Profile".
4. Enter the title, select the avatar and color code.
5. Tap "Save" .

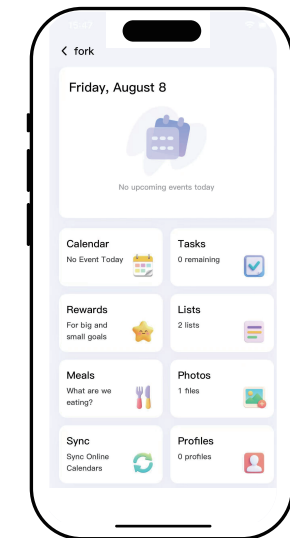

3.Operation Instruction

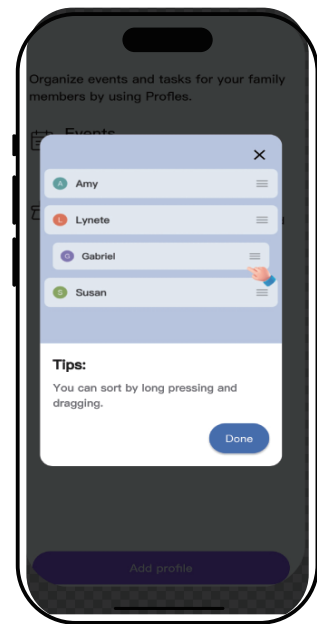

2

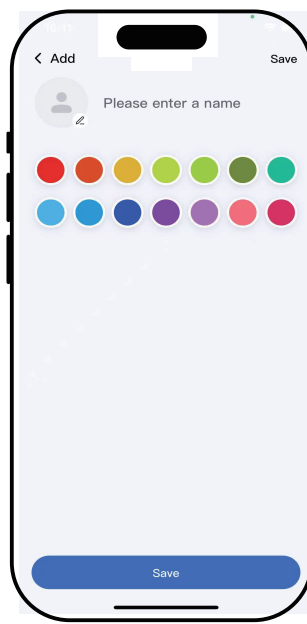

3



4



5

3.Operation Instruction

Tips: Profiles can also be added when creating new events or tasks. (Supported on both device and application platforms)

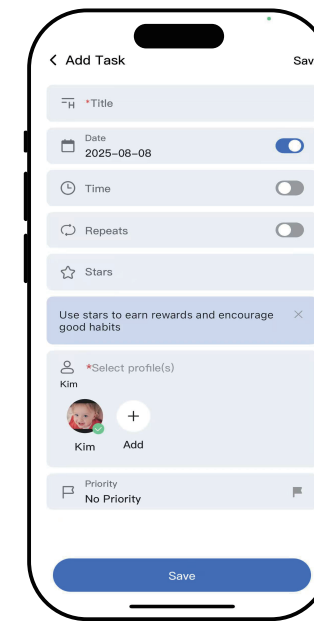
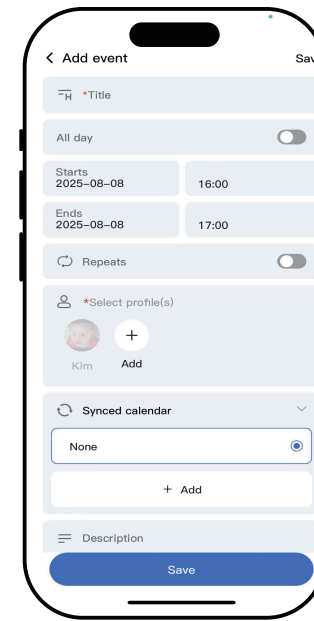

3.Operation Instruction

3.7.2 Delete Profile

Only the mobile device supports deleting Profile information

- 1.Select the Profile information to be deleted.
- 2.Jump to the page of Edit Profile.
- 3.Tap Delete all.
- 4.Then "Are you sure to delete?" will pop up,and choose I'm sure.

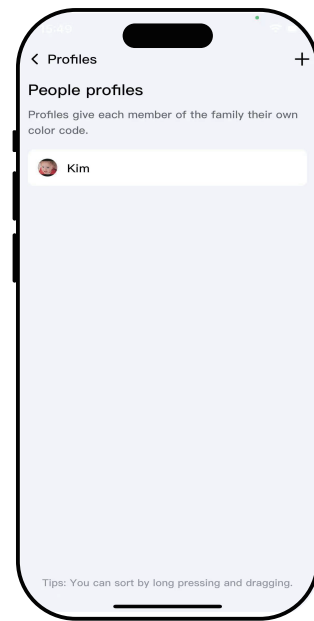

1



2



3

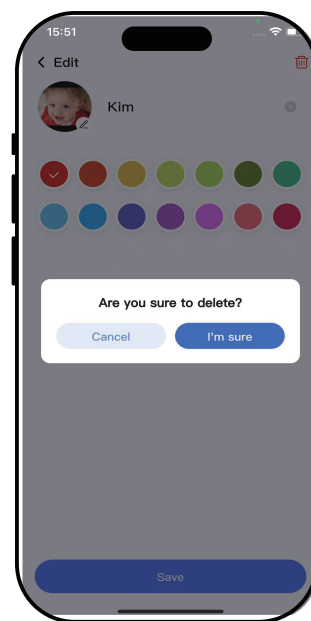

4

3.Operation Instruction

Tips:1. Profiles with linked events or tasks cannot be deleted until all associated items are removed. Ensure these dependencies are cleared first, then proceed with profile deletion.

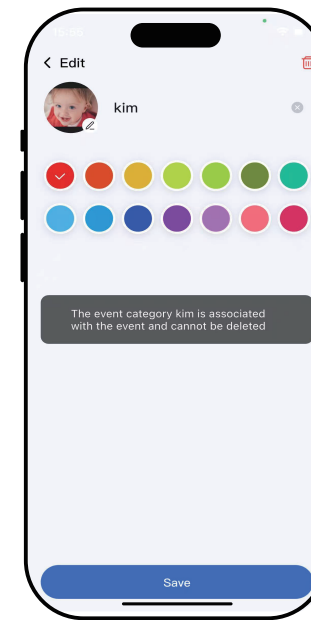

3.Operation Instruction

2.Alternatively, use 'Delete and Reassign' to automatically transfer all linked events/tasks to another team member before removing the profile.

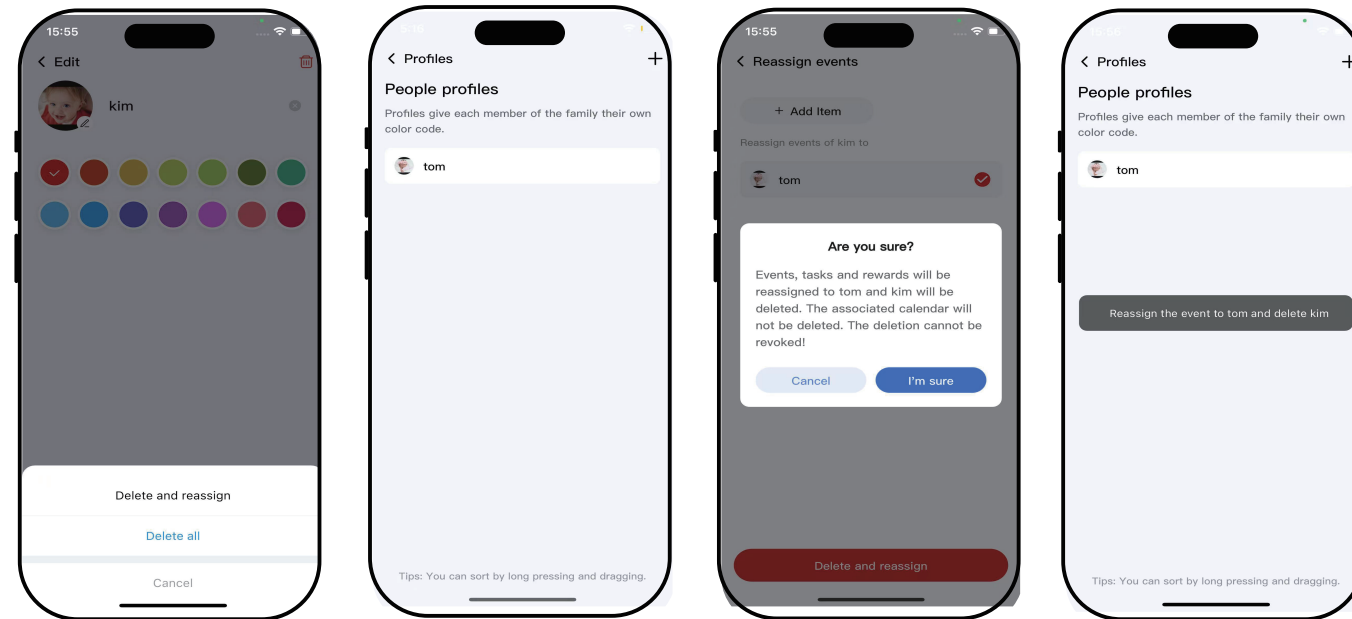

3.Operation Instruction

3.8 Weather

1. Click the weather icon in the upper left corner of the home page. (You can choose to hide the weather display in the Settings.) Search for the temperature of any city and set it to display on the home page.
2. Click the C°/F° icon to display the air temperature at “F°” or “C°” .
3. The weather forecast for the current day and the next day will be displayed in advance.

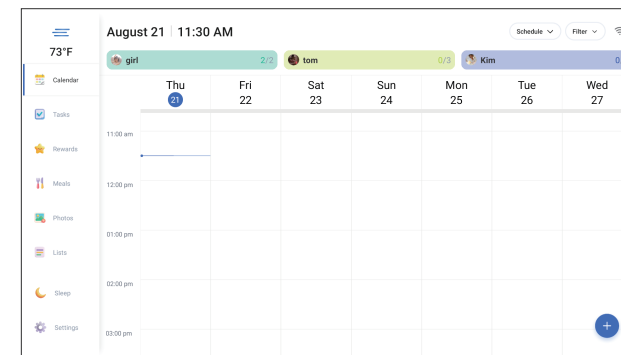
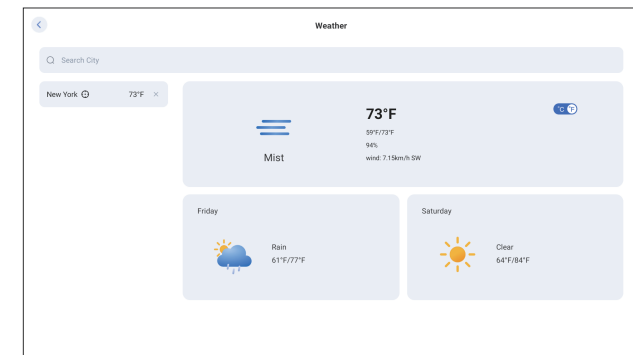
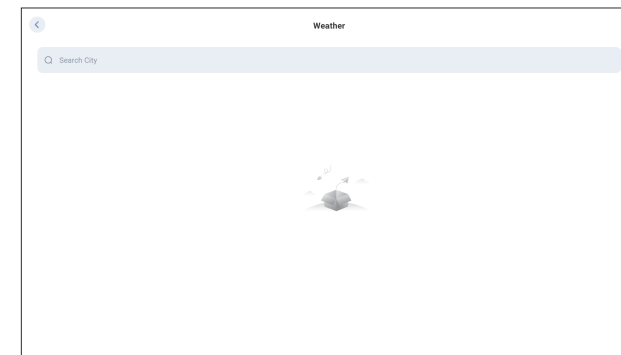

4.Magic Import

Support for sending video, picture, and files to a virtual calendar email address from third-party email services to import video, picture and files(PDF, Excel,Word,TXT). When the device receives a files, it will automatically parse it as an image or an event. (an item is considered an event if it include a title and a start date.)

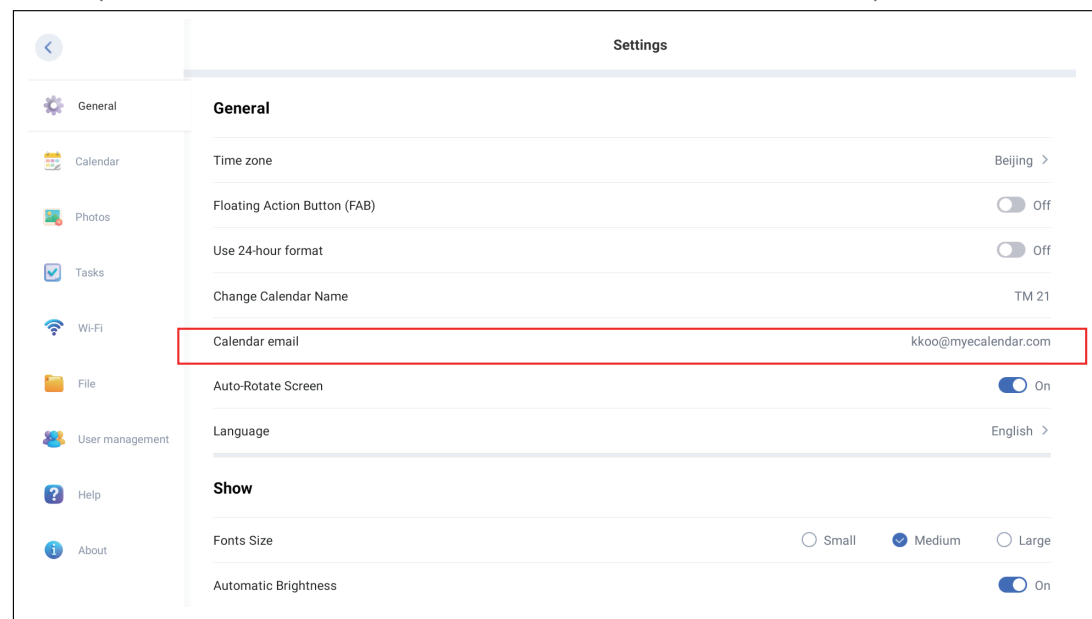

5.Sleep Mode

Sleep Mode turns off your eCalendar's display during scheduled intervals. Make sure your device's time zone is set properly in Settings ->  Configure Time Zone. Sleep Mode can only be configured from the device.

5.Sleep Mode

Scheduled Sleep and Instant Sleep

1. Tap the moon icon located at the bottom of the sidebar.
2. Toggle on "Sleep Mode Schedule" and select the time for your Calendar to go to sleep and wake up. Press "Save" to confirm. When your Calendar is in Sleep Mode, you can press the power button at any time to wake it up.
3. Tap "Enter Sleep Mode Now" to turn off the display. Press the power button again to wake up your eCalendar.

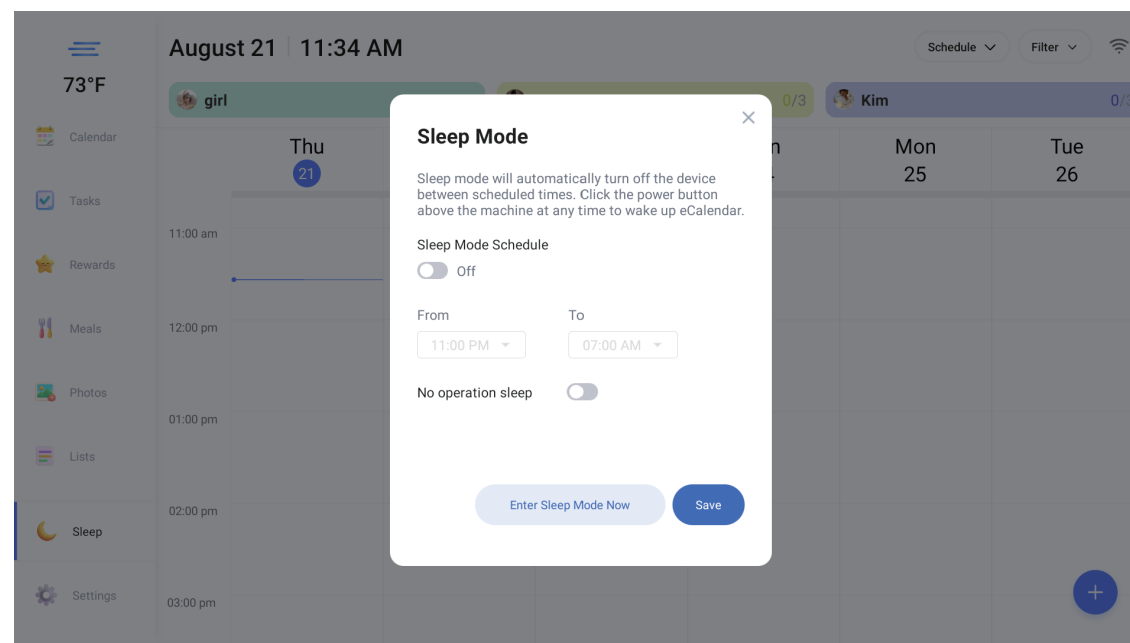

6.Settings

Settings

Settings -> General -> Font Size & Time Zone

1. Choose from Small, Medium, or Large font sizes in "Settings."
2. Change the time zone and language settings.
3. Tap the "Reset Device" icon to clear all data on the device.

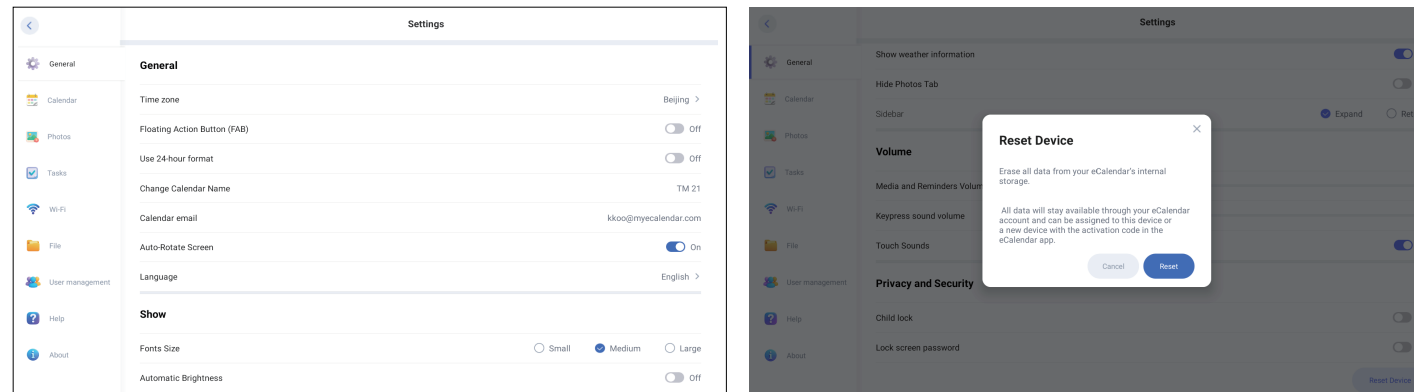

6.Settings

Settings -> Calendar -> Reminder

1. Reminders

You can enable reminders on your eCalendar to alert you about upcoming events.

(Tip: The reminder sound plays only once, but the reminder pop-up will remain displayed on the screen until dismissed. If previous reminder pop-ups are not dismissed, new ones will stack and display together on the screen.)

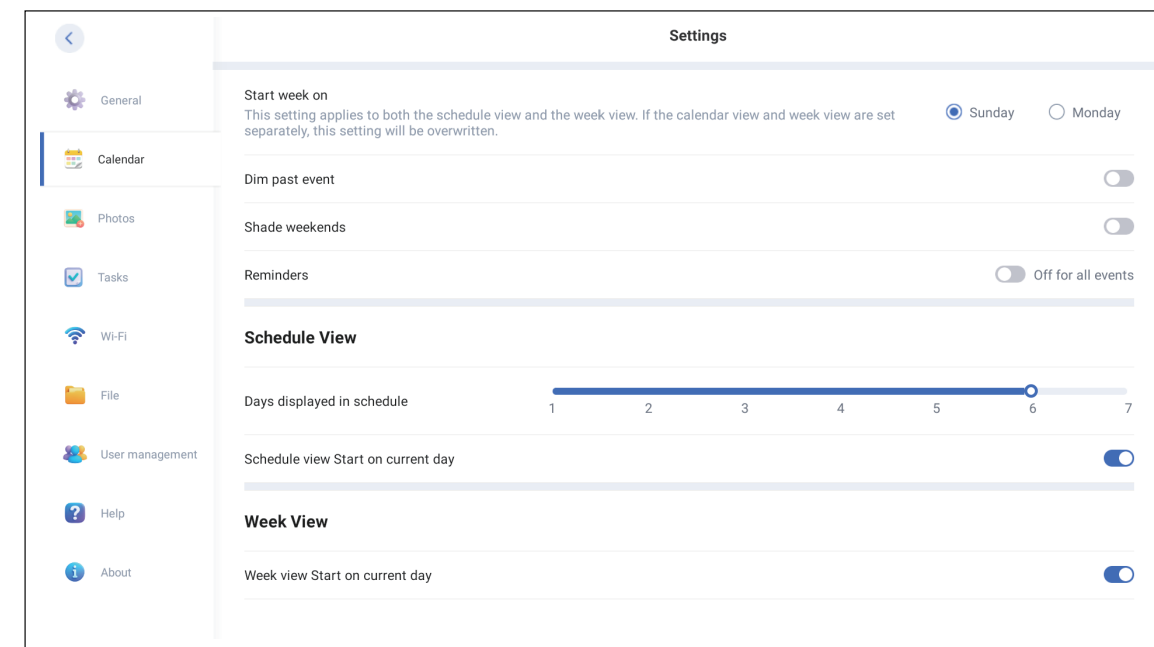

7. Installation Instruction

7.1 Position and drill in the screws

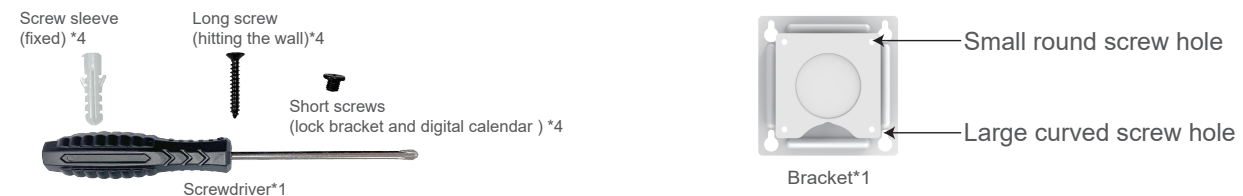

- ① Choose the wall surface to hang the product.

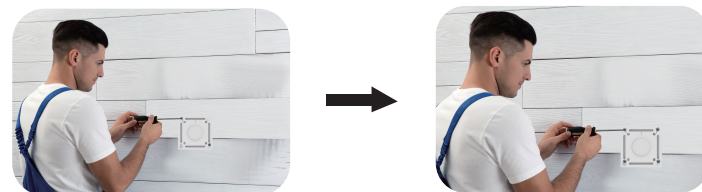

- ② Place the bracket on the wall to be drilled and align the large curved screw hole position of the bracket (outermost four hole positions) to determine the drilling position.



- ③ Secure the four holes with black screws (as shown above), insert the white nail bar (as shown above) into the four drilled holes, and then insert the four black screws.

NOTE: The four screws should not be completely buried in the holes, leave some room for the bracket to hang.

7. Installation Instruction

7.2 Lock the bracket with the digital calendar

- ① Plug in the digital calendar

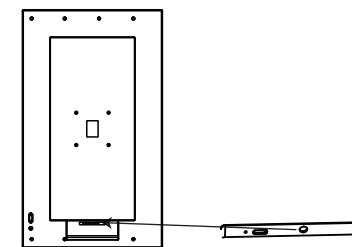

- ② Place the side of the bracket with the groove facing downwards, then align the four small round screw holes (the four holes inside) on the bracket with the four holes on the digital calendar.

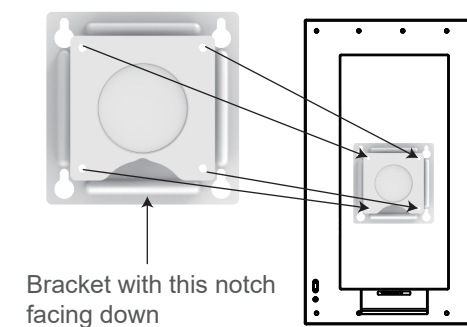

- ③ Lock the holes aligned in step two one by one with short screws.

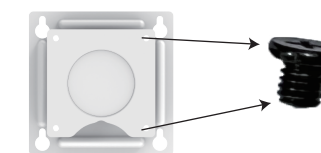

- 7.3 Hang the digital calendar on the wall by aligning the large curved screw holes (four outermost holes) with the four black screws on the wall.

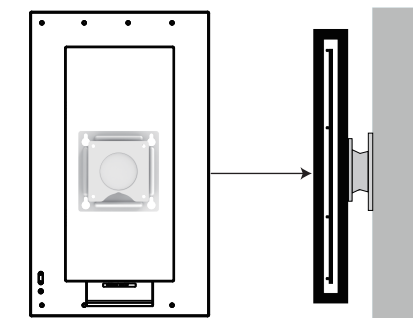

(Schematic diagram of the wall on the side)

8. Technical Specifications & Features

Technical Specifications & Features						
Display	10.1"(16:10)	15.6"(16:9)	21.5"(16:9)	24"(23.8")(16:9)	27"(16:9)	32"(16:9)
Resolution	1280*800 Pixels	1920 * 1080 Pixels	1920 * 1080 Pixels	1920 * 1080 Pixels	1920 * 1080 Pixels	1920*1080 Pixels
Built-in Memory	32GB	32GB	64GB	64GB	64GB	64GB
Built-in WIFI	Dual WiFi 2.4G+5G	Dual WiFi 2.4G+5G	Dual WiFi 2.4G+5G	Dual WiFi 2.4G+5G	Dual WiFi 2.4G+5G	Dual WiFi 2.4G+5G
Touch Screen	√	√	√	√	√	√
Main Function	Dual-WiFi+Event Management+Chore Chart+ To-Do Lists+Photo Display+Sync Calendars + Categories +Dinner Planner+Weather Station+Full HD Movie+Sleep Mode +Reminders					
Interface	DC IN	Type-C	Type-C	Type-C	Type-C	TF Card Slot & USB 2.0 &Type-C
OSD Languages	OSD Language & Multiple Language OptionsOSD					
Software	In-house R&D Software eCalendar APP Supported by World Famous Cloud System					
Adapter	Input AC100-240V~50/60Hz1.5A Output DC5V/2A	Input AC100-240V~50/60Hz1.5A Output DC12V/1.5A	Input AC100-240V~50/60Hz1.5A Output DC12V/3A	Input AC100-240V~50/60Hz1.5A Output DC12V/3A	Input AC100-240V~50/60Hz1.5A Output DC 19V/2A	Input AC100-240V~50/60Hz1.5A Output DC 19V/3.15A
Working Temperature	0C~40℃,Humidity:10-85%					
Accessories	Use Manual, Adapter, Desk bracket	Use Manual, Adapter, Desk Bracket and Wall mounted Accessories	Use Manual, Adapter, Desk Bracket and Wall mounted Accessories	Use Manual, Adapter, Desk Bracket, Wall Amount Rotating Accessories	Use Manual, Adapter, Desk Bracket, Wall Amount Rotating Accessories	Use Manual, Adapter, Wall Amount Rotating Accessories

9. Warranty & Contact Us

Warranty

Our warranty is 12 months from the date of purchase. This warranty becomes invalid if the factory-supplied serial number or "warranty void" sticker has been removed or altered on the product.

This warranty does not cover.

1. Appearance damage or artificial damage.
2. Accident, misuse, abuse, negligence or modification of any part of the product
3. Damage due to improper operation or maintenance, connection to improper equipment or attempted repair by anyone else, not from us.

Contact Us

For any inquiries and after-sales service requirements , or product user experience feedback , please feel free to contact us.

Email: support@mycalendar.com

10.Troubleshooting Guide

If you come across when using the digital calendar on problems, consult the suggested solutions below, and the corresponding sections of this manual. If you need additional assistance, please contact technical support.

1.Device fails to power on

- Check the power connection: Make sure the device is properly connected to the power adapter, the plug is firmly inserted, and the outlet is powered.
- Restart the device: hold down the power button to restart the device.

2.Unable to connect to Wi-Fi

- Check network status: Make sure the router is working properly and connected to the Internet.
- Verify Wi-Fi Password: Ensure that you have entered the correct password.
- Restart your device and router: Try restarting your electronic calendar and router.
- Check the Wi-Fi band: The device may only support 2.4GHz or 5GHz, make sure the router band is compatible.

3.Screen touch is not responsive

- Clean the screen: Wipe the screen with a clean, soft cloth to avoid stains affecting the touch.
- Restart the device: Hold down the power button to shut down the device and restart it.
- Check for system updates: Make sure the system is updated to the latest version.

4.Unable to sync calendar or photos

- Check network connection: Make sure the device is networked and maintains a stable network connection.
- Checking the login account: Ensure that the device login account is the same as the synchronization account.
- Update the app: Make sure you are using the latest version of the app.
- Regrant synchronization permissions: Check and regrant synchronization permissions in Settings.

10.Troubleshooting Guide

5.The device responds slowly or stutters

- Clean up storage: Delete unnecessary files, photos, or apps.
- Restart the device: Shut down and restart the device to release the memory.
- Check applications: Close unused background applications.
- Restore Factory Settings (only if necessary) : After backing up the data, select Restore factory Settings in the Settings.

6.Unable to play audio or video

- Check volume Settings: Confirm that the device is not silent and adjust the volume to an appropriate level.
- Check file format: Ensure that the file format is compatible with the format supported by the device.
- Restart the device: Try to shut down and restart the device

7.The device automatically shuts down or restarts

- Check the temperature of the device: The device may automatically shut down due to overheat. Avoid use in high temperature environment.
- Check the battery status: If the battery is low, the device may shut down automatically. Please charge it in time.
- Update system firmware:Ensure that the device is running the latest system version.

8.Unable to update the system or application

- Check the network connection: Ensure that the device is properly connected to the network
- Check storage space: Ensure that the device has sufficient storage space for updates.
- Try manual update: Go to Setting check and perform system or application updates.

10.Troubleshooting Guide

9.Can the video sound be adjusted?

- Yes, it can be adjusted.①Tap Setting on the buttom of left.②Click General.③Slid to adjust the sound on Media and Reminder Volume.

10.Can the eCalendar be displayed in both landscape and portrait orientation?

- The eCalendar supports both landscape and portrait orientation display.

11.Can the brightness of the eCalendar be adjusted?

- Yes. You can adjust it yourself according to your needs.just turn off the automatic brightness,then you can slide to adjust the brightness.

12.Can you sync one calendar or multiple calendars?

- Yes. You can sync as many calendars as you want.

13.Does the eCalendar have a subscription fee?

- Yes. But you can choose to pay or not to pay extra depending on your needs.

14.Can I use the eCalendar without connecting to WiFi?

- Yes, but the eCalendar cannot be edited, only previewed. If you want to operate an electronic calendar, it needs to be connected to the Internet.

15.How to enable 2-Way-Sync?

- If you've already synced your Google calendar and would like to enable Two-Way Sync, we recommend first deleting the calendar before attempting to sync it again.
- All of your existing Google calendar events will be imported when you re-sync, so there's no risk of losing those events.
- While syncing your Google calendar, you'll need to select "Two-Way Sync" during set up or newly created events will not appear on your Google calendar.

10.Troubleshooting Guide

16.How can I ensure that Google Calendar events sync to eCalendar?

- Android Devices: After creating a new event in the Google Calendar app, you need to manually tap the "Refresh" button in the sidebar to sync the event to the eCalendar.
- iPhone: Events created on an iPhone are automatically synced to the eCalendar without additional actions.

17.What types of Google Calendar events are supported by eCalendar?

- eCalendar supports syncing event types only. Task types are not supported.

18.How long does it take to sync events from third-party calendars to eCalendar?

- Google Calendar and Outlook: Syncing takes approximately 1 minute.
- iCloud, Yahoo, and Cozi: Syncing takes between 1 and 30 minutes, with a minimum of 1 minute and a maximum of 30 minutes.

19.Can the digital calendar be used on battery power?

- No, the digital calendar is powered by a direct AC adapter and does not have a built-in battery.

11.Firmware Upgrade Instructions

Mobile App Update

(1) Android OS: Download the latest version from Google Play.

- ① Open Google Play on your phone.
- ② Tap the search bar, enter "eCalendar" and search.
- ③ Tap the Download or Update button.

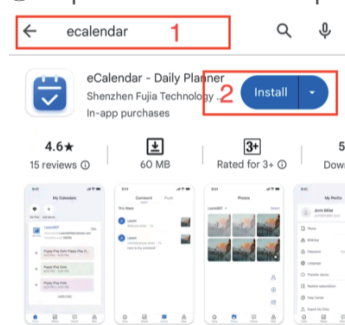

(2) iOS OS:Download the latest version from Apple Store.

- ① Open Apple Store on your phone.
- ② Tap the search bar, enter "eCalendar" and search.
- ③ Tap the Download or Update button.

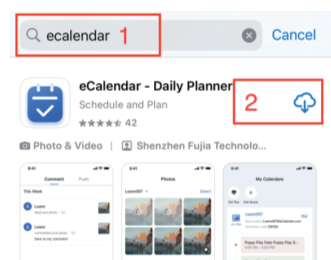

Screenshots for Upgrade Steps:

Please check the calendar version number on the about page of the settings.

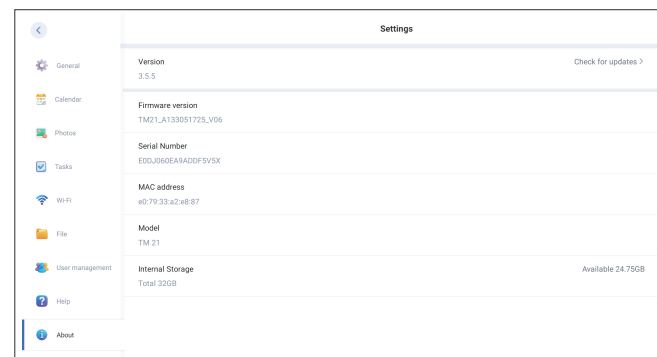

(1) Version 1.4.13 and Earlier: Manually click check for updates to upgrade as follow:

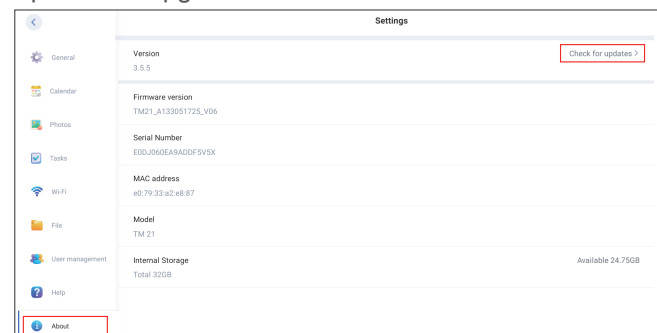

11.Firmware Upgrade Instructions

Screenshots for Upgrade Steps:

(2) Version 1.4.13 and Later and version 2.1.45 Earlier: Upgrade pop-up reminder display when restart, click Upgrade immediately to update,if you click x,Upgrade pop-up reminder display again when restart.

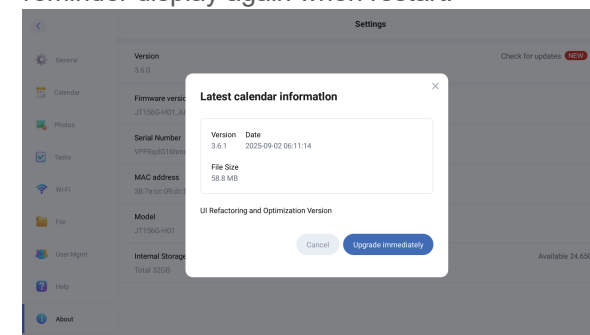

(3) Version 2.1.45 and Later:

① An upgrade pop-up prompt will appear (you can choose to turn off or automatically upgrade) if you turn off the Automatic upgrade button in About page.

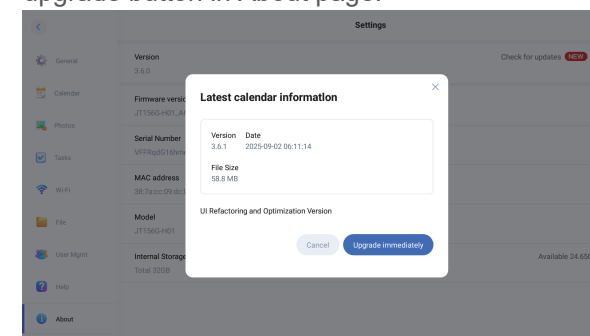

② When you enable the Automatic upgrade button in version version 2.1.45 and Later, the device will auto upgrade when turned on the device.Pop-up window showing downloading upgrade.

